

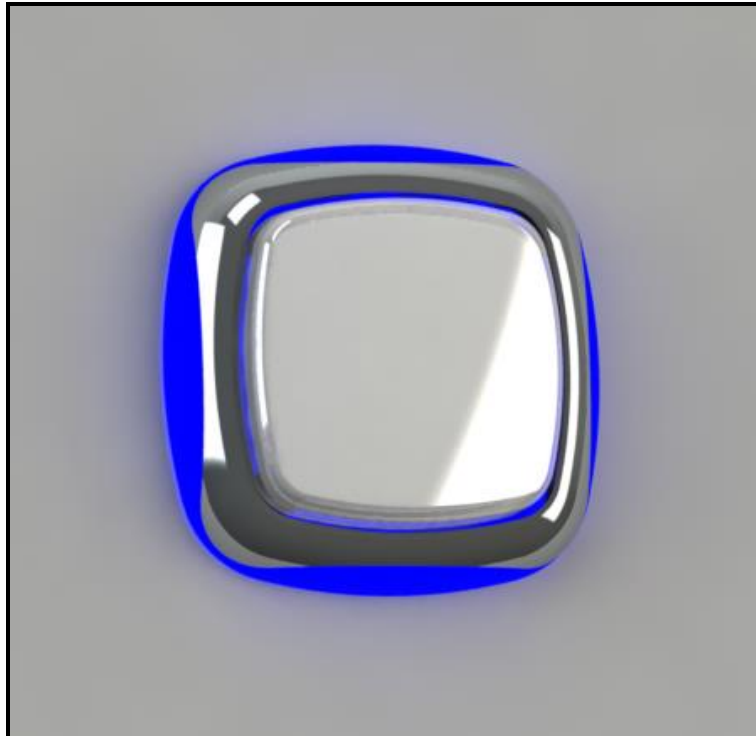

Gamesman

# GPB1210 Push Button Product Specification

Issue 08: Date 03.11.2022



Disclaimer:

The information provided within this product specification is intended only to make the reader aware of the product's technical data and its use thereof. As such, Gamesman Ltd shall not be held liable for any loss or damage to the assembly or component within, arising from its misuse or from the unintended use of information or particulars included within, or any omission from, this document.

Design and specifications are subject to change without notice.

Failure to observe the interface requirements specified in this document may result in damage to the electronics and resultant performance characteristics of the product.

DRAWING No.  
**GDD02400**

THIS DRAWING AND ANY INFORMATION SET OUT HEREON IN ARE THE CONFIDENTIAL PROPERTY OF GAMESMAN AND MUST NOT BE DISCLOSED, LOANED, COPIED OR USED FOR ANY OTHER PURPOSE WITHOUT WRITTEN PERMISSION.

DESIGN COPYRIGHT RESERVED.  
DO NOT SCALE.  
THIRD ANGLE PROJECTION.  
DIMS TO APPLY AFTER PLATING.

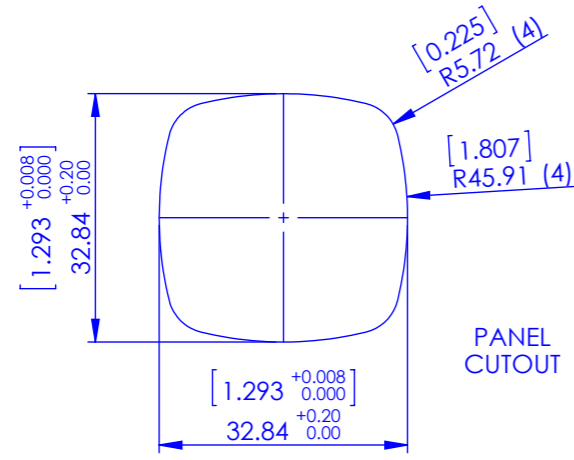

PANEL CUTOUT

PANEL THICKNESS:  
MIN: 1.40 [0.055]  
MAX: 2.00 [0.079]

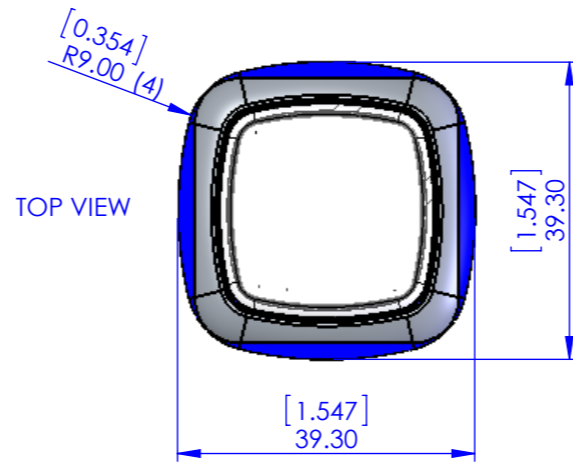

TOP VIEW

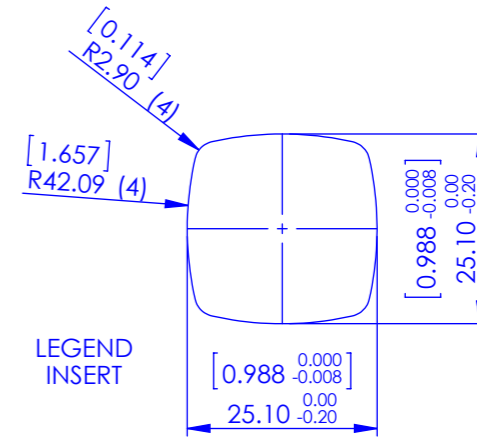

LEGEND INSERT

INSERT THICKNESS:  
MAX: 0.30 [0.012]

BUTTONS VIEWED FROM TOP

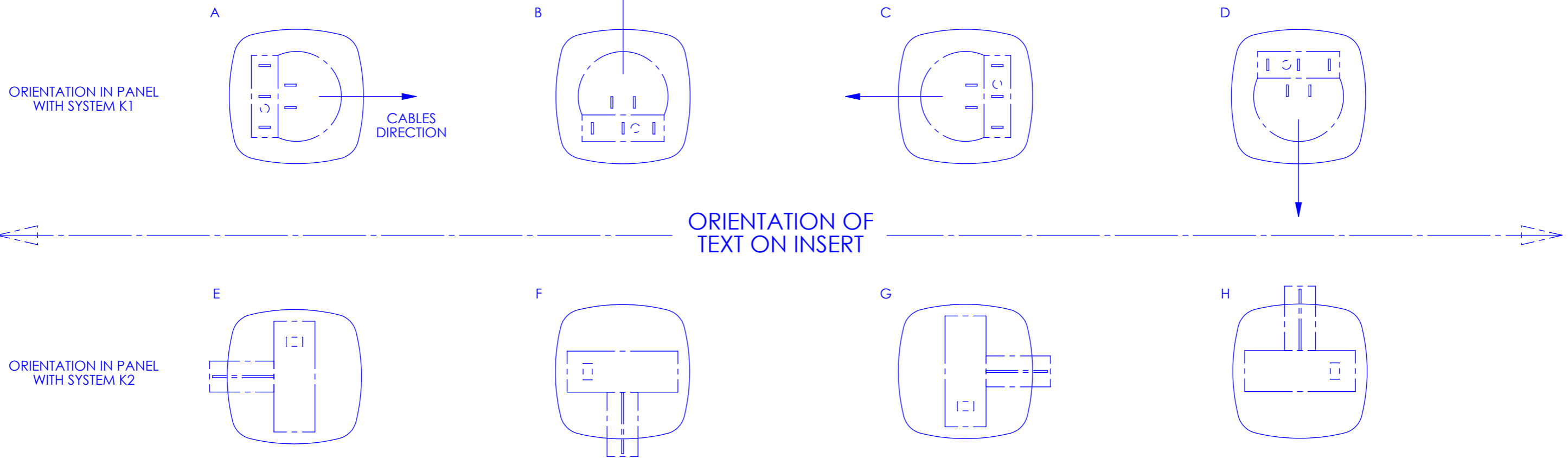

APPROVED	<p>Unit 6, Crompton Fields, Crompton Way Crawley, West Sussex, RH10 9QB, UK Tel: +44(0)1293 418888 Fax: +44(0)1293 418880 <a href="http://www.gamesman.co.uk">http://www.gamesman.co.uk</a></p>	THIS PART MUST BE RoHS COMPLIANT	DIMS	SCALE	3	03/07/2012	ECN-1353	PANEL CUT-OUT INCREASED	V.PORTILLO	
			mm	1:1	2	19/06/2012	ECN-1349	THICKNESSES OF PANEL AND INSERT ADDED	V.PORTILLO	
DRAWN	V.PORTILLO DATE 23/05/2012	FINISH SEE PART DRAWING MATERIAL SEE PART DRAWING	TOLERANCES UNLESS OTHERWISE SPECIFIED: 0.00 DIMS ±0.13 0.0 DIMS ±0.40 ANG ±0.5°, DRAFT ±1° PER SIDE CONCENTRICITY ±0.08 MAX ○ - DENOTES INSPECTION DIMENSION	1 23/05/2012 NEW DRG DRAFT ISSUE	ISS.	DATE	ECN NUMBER	REVISION DETAILS	NAME	
TITLE					SIZE	SHEET	DRAWING No.			
					GPB1210 SPECIFICATION			A3	1 of 1	<b>GDD02400</b>

DRAWING No.  
**GDD02399**

THIS DRAWING AND ANY INFORMATION SET OUT HEREON IN ARE THE CONFIDENTIAL PROPERTY OF GAMESMAN AND MUST NOT BE DISCLOSED, LOANED, COPIED OR USED FOR ANY OTHER PURPOSE WITHOUT WRITTEN PERMISSION.

DESIGN COPYRIGHT RESERVED.  
DO NOT SCALE.  
THIRD ANGLE PROJECTION.  
DIMS TO APPLY AFTER PLATING.

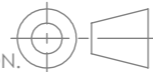

**BOTTOM SHOT IN ANY TRANSLUCENT COLOUR (OR OPAQUE IF HALO IS NOT DESIRED)**

**STANDARD HALO**

**TOP SHOT IN ANY COLOUR (CHROMING AVAILABLE)**

**CONTROLLABLE RGB HALO**

**BOTTOM SHOT IN:**  
-CLEAR, FOR A HOT-SPOT STYLE HALO  
-OPAL, FOR A DIFFUSED HALO

BEZEL AND LENS HEIGHT DIMENSION COMMON ON ALL 1200 BUTTONS

[0.378] 9.60  
[0.236] 6.00

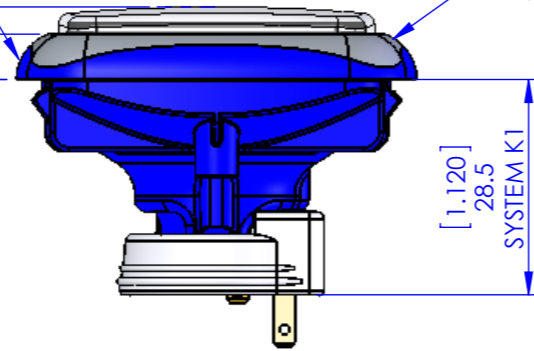

[1.120] 28.5  
SYSTEM K1

[1.766] 44.9  
SYSTEM K2

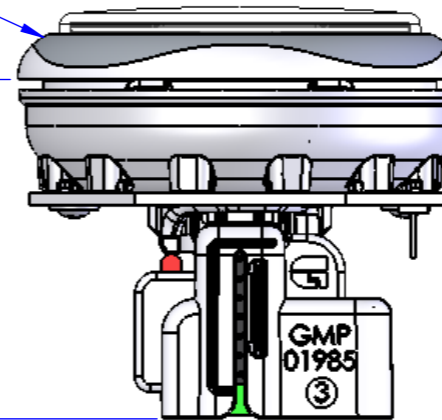

HALO BOARD AND SLEEVE SCREWED BEHIND THE PANEL AFTER BUTTON IS CLIPPED INTO THE PLATE

FOR STANDARD HALO, GAMESMAN RECOMMENDS 5 LEDS CENTRAL ILLUMINATION

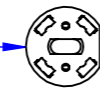

FOR CONTROLLABLE RGB HALO CONFIGURATION, GAMESMAN RECOMMENDS 1 LED CENTRAL ILLUMINATION



ALL CONNECTION SYSTEMS FIT IN THE SAME BUTTON AND CAN BE USED WITH ANY BUTTON CONFIGURATION

SYSTEM K1 (SMALL SWITCH)

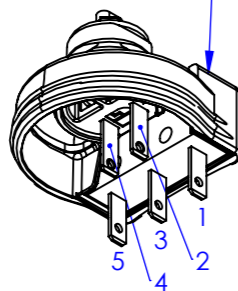
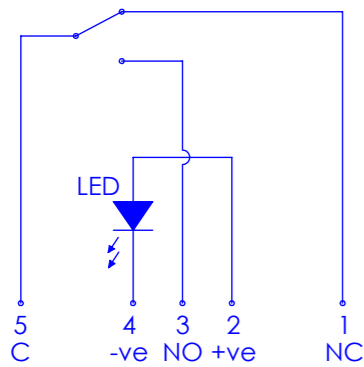

SYSTEM K2 (LARGE SWITCH)

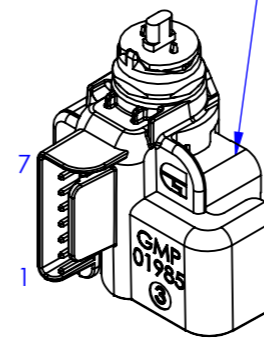
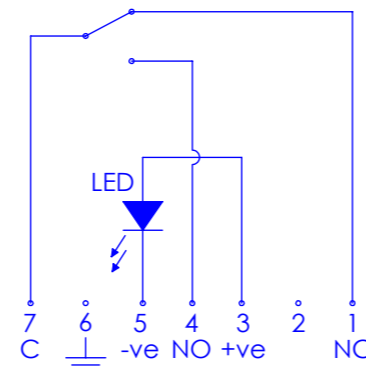

SYSTEM K3 (LARGE SWITCH)

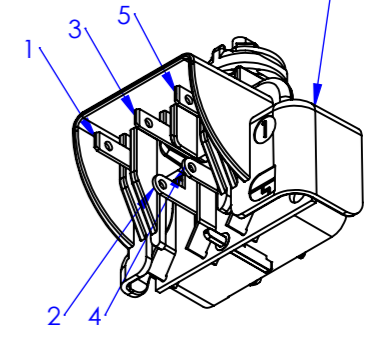
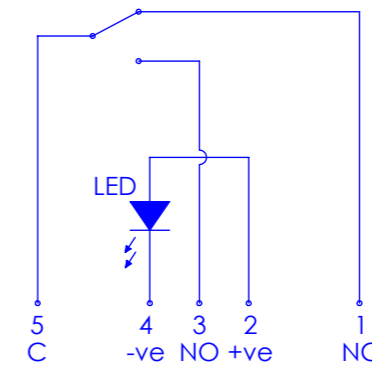

THIS DRAWING SHOULD NOT BE TAKEN AS REFERENCE FOR PART NUMBERS - SEE ASSOCIATED BUTTON SPEC SHEET

APPROVED	<p>Unit 6, Crompton Fields, Crompton Way Crawley, West Sussex, RH10 9QB, UK Tel: +44(0)1293 418888 Fax: +44(0)1293 418880 <a href="http://www.gamesman.co.uk">http://www.gamesman.co.uk</a></p>	THIS PART MUST BE RoHS COMPLIANT	DIMS	SCALE	3 08/10/2012 ECN-1394 K3 SYSTEM ADDED V.PORTILLO 2 14/09/2012 ECN-1382 BEZEL AND LENS HEIGHT DIMENSION INCLUDED V.PORTILLO 1 21/05/2012 NEW DRG DRAFT ISSUE V.PORTILLO ISS. DATE ECN NUMBER REVISION DETAILS NAME	SIZE A3 SHEET 1 of 1 DRAWING No. <b>GDD02399</b>	
DRAWN			FINISH	TOLERANCES UNLESS OTHERWISE SPECIFIED:			TITLE
DATE			MATERIAL	0.00 DIMS ±0.13 0.0 DIMS ±0.40 ANG ±0.5°, DRAFT ±1° PER SIDE CONCENTRICITY ±0.08 MAX ○ DENOTES INSPECTION DIMENSION			1200 SERIES SPECIFICATION
V.PORTILLO	SEE PART DRAWINGS	SEE PART DRAWINGS	1:1				
15/05/2012							

**Product Identification**

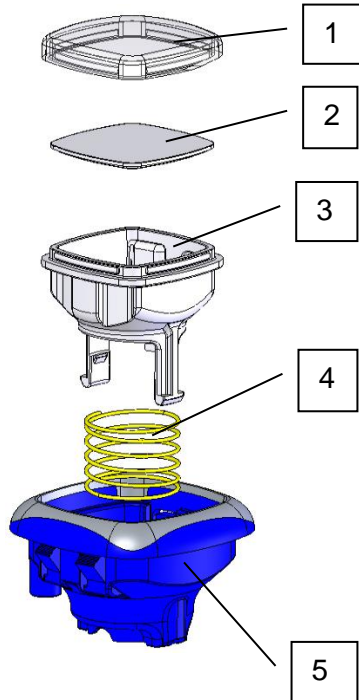





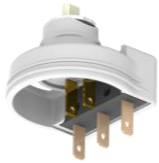

No.	Part Number	Description	Material	UL94 Rating
1	GMP02368	Lens	PC	UL94-V2
2	GMP02367	Legend Plate	PC	UL94-V2
3	GMP02366	Plunger	POM	HB
4	G4-950	Spring	Carbon Steel	N/A
5	GMP02365	Bezel	PC and ABS	HB and UL94-V2

**Note:**

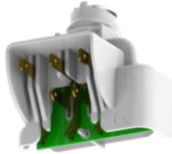
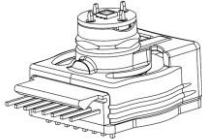
Item 5 is a “two shot” moulding, and therefore available in various colour combinations – see the button specification sheet for potential options. \*Minimum order quantities may apply\*

## Product Compatibility

System	K1	K2	K3	K7
Illustration				
Datasheet				
Switch	Cherry DB3 or Cherry DB5	Cherry Large Tactile ( <b>NO</b> & <b>NC</b> options for RGB)	Cherry Large Tactile	Cherry DB3 or Cherry DB5
White LED Options	12V or 5V, Single LED or 5 Radial LEDs	12V or 5V, Single LED or 5 Radial LEDs	12V or 5V, Single LED or 5 Radial LEDs	12V or 5V, Single LED or 5 Radial LEDs
RGB Option	No	Yes, Single RGB	No	Yes, Single & 3-RGB Options
Removable LEDs	No	Yes	Yes	No
<b>Order Codes for Separate LED Assemblies</b>				
System	K1	K2 & K3		K7
12V White Single LED	N/A	0927-G02207		N/A
12V White Radial 5-LED	N/A	0927-G01986		N/A
5V White Single LED	N/A	Please Enquire		N/A
5V White Radial 5-LED	N/A	0927-G03271		N/A
12V Red Radial 5-LED	N/A	0927-G04818		N/A
12V Blue Radial 5-LED	N/A	0927-G04776		N/A
12V Green Radial 5-LED	N/A	0927-G04816		N/A
12V White Single LED Reverse Polarity	N/A	0927-G02843		N/A
12V White Radial 5-LED Reverse Polarity	N/A	0927-G02844		N/A

Gamesman recommends Single Axial Central LED Option for Controllable Halo Versions & 5 Radial x LED Option (1 central and 4 side firing) for non-Controllable Halo Versions



For more details see the Gamesman Specification sheet for this button.

[GPB1210.xls](#), and details of various switch connection systems.

## Accessories and Options

### Halo Boards

Halo boards are separately powered LED PCBAs that are specifically mounted to the button of a button, for the purpose of illuminating the outer bezel. For multicolour RGB illumination, Gamesman recommends using Opal Bezels for this purpose. Additional Sleeves and screws are required to mount and illuminate the Halo Board correctly.

Part Number	Type / Colour
<a href="#">0927-G02370</a> 	<b>RGB – Memory – Pre-Programmed – 5v (Option 1)</b>  This option consists of a memory chip located on the halo PCBA itself. This chip contains a pre-determined, pre-programmed LED sequence uploaded at the time of manufacture so that when voltage is applied, the PCBA automatically runs this sequence. As there is no independent 'control' of the LEDs this only has a 2pin connector – power and ground.
<a href="#">0927-G02373</a> 	<b>RGB – Without Memory – Controllable from External Source - 5v (Option 2)</b>  This option does not have the memory chip on board and as such will not automatically run a sequence when voltage is applied. However, it does have a 7way connector with pins that allow the customer to control the LEDs independently using their own LED controller board, via serial communication.

### Panel Mounting Options

The GPB1200 Series buttons feature Panel Mount clips that will secure the button to a metal panel up to 2mm thick (Including any additional coating or finish), with no additional hardware required. For customers who would like to use an additional Halo Board (See above), Gamesman can advise and supply sleeves and screws for a customer's cabinet.

#### Details of Securing the Sleeve, PCBA and Screw to Button

- 1) Insert Button into the panel from the front of the machine.
- 2) Lining up the fixing holes up in the Bezel, Sleeve and (optional) Halo PCB, use the screws provided to secure the Sleeve from the rear of the panel.
- 3) Lastly, snap the switch holder into the bezel.

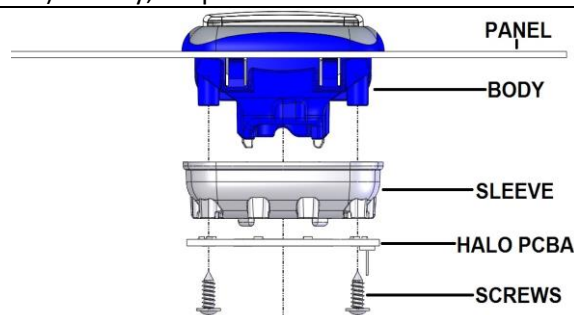

#### Sleeve and Screws Only

In addition to securing the Halo PCBA, the sleeve and screws can also be used by themselves to provide further security to thicker panels. Maximum allowances for this button per switch system is as follows:

K1	K2	K3	K7
8mm	7.5mm	8mm	5mm

Tools

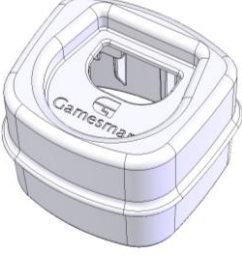
<p>Extraction Tool for Button Order Part Number GMP02372</p>	<p>Insertion/Extraction Tool for K1, K2 and K3 Switch Order Part Number GMP02791</p>
	

## **Additional Ordering Details**

### **Specification Sheet**

Click the link below to complete a specification sheet of your requirements. If you have any questions regarding your options that are not covered in this document, please contact our Sales team.

[GPB1210.xlsx](#)

### **Packaging**

Standard Packaging format for these buttons:

For Buttons **without a Halo Board, Sleeves or Screws:**

Lens & Legend Packed Separately in Bulk  
Switch Connection System Assembled to the Button  
Button Assembly Packed in Trays

For Buttons **with a Halo Board, Sleeve or Screws:**

Lens & Legend Packed Separately in Bulk  
Switch Connection System to be loosely fitted into button  
Button/Switch Assembly Packed in Trays  
All Halo parts packed in bulk as kit of parts PER BOX (Sleeve, Screws & LED PCBA)

For any deviations from this please refer to specification sheet.

### **Space Models**

3D CAD models link here, for other combinations please contact our Sales team.



# Gamesman

GAMESMAN LTD

CROMPTON FIELDS, CROMPTON WAY, CRAWLEY, WEST SUSSEX, RH10 9QB

TEL: +44 (0) 1293 418888 FAX: +44 (0) 1293 418880

**REGISTERED IN ENGLAND NO. 3027138**

Website: [www.gamesman.co.uk](http://www.gamesman.co.uk)

E-mail: [sales@gamesman.co.uk](mailto:sales@gamesman.co.uk)