

NV9 Spectral Range Manual

[<< Back to Contents](#)

Document Name:	User Manual - NV9 Spectral Range Manual
Document Version:	1.1
Date of Release:	26/04/2019

TABLE OF CONTENTS

1	DOCUMENT INTRODUCTION	4
1.1	RELATED DOCUMENTS	4
1.2	MANUAL AMENDMENTS	4
1.3	COPYRIGHT	4
1.4	LIMITED WARRANTY	5
1.5	PRODUCT SAFETY INFORMATION	5
2	PRODUCT INTRODUCTION	7
2.1	GENERAL DESCRIPTION	7
2.2	KEY FEATURES	7
2.3	TYPICAL APPLICATIONS	7
2.4	COMPONENT OVERVIEW	7
2.4.1	<i>NV9 Spectral (NV9S)</i>	7
2.4.2	<i>NV22</i>	8
2.4.3	<i>Interface Connectors</i>	9
2.4.4	<i>Configuration Button Functionality</i>	11
2.4.4.1	Configuration Button Press Functions	12
2.4.4.2	Bezel Interface Flash Counts	12
2.4.5	<i>Bezel Options</i>	13
2.4.6	<i>Cashbox Options</i>	13
3	TECHNICAL DATA	14
3.1	DIMENSIONS	14
3.1.1	<i>NV9 Spectral Dimensions</i>	14
3.1.2	<i>NV22 Dimensions</i>	15
3.2	WEIGHT (WITHOUT NOTES)	15
3.3	ENVIRONMENTAL REQUIREMENTS	15
3.4	POWER REQUIREMENTS	16
3.4.1	<i>Supply Voltages</i>	16
3.4.2	<i>Supply Currents</i>	16
3.4.3	<i>Power Supply Guidance</i>	16
3.5	INTERFACE LOGIC LEVELS	16
3.6	RELIABILITY DATA	17
3.7	MEDIA REQUIREMENTS	17
3.7.1	<i>Notes</i>	17
4	MECHANICAL INSTALLATION	18
4.1	COMPATIBILITY	18
4.1.1	<i>Hardware Compatibility</i>	18
4.1.1.1	Machine mounting	18
4.1.1.2	Machine interfacing	18
4.1.1.3	Power Supply	18
4.2	SOFTWARE COMPATIBILITY	19
4.2.1.1	Interface protocols	19
4.2.2	<i>Re-programming</i>	19
4.3	BEZEL MOUNTING	20
4.3.1	<i>Bezel Removal</i>	20
4.3.2	<i>Bezel Fitting (Standard Bezel)</i>	21



NV9 Spectral Range Manual

[<< Back to Contents](#)

4.4	CASHBOX MOUNTING	22
4.4.1	<i>Cashbox Removal</i>	22
4.4.2	<i>Cashbox fitting (slide on cashbox)</i>	23
4.5	REMOVING THE BLANKING PLATE	24
4.6	MOUNTING MULTI NOTEFLOAT	25
4.7	REMOVING MULTI NOTEFLOAT	26
5	SOFTWARE INSTALLATION AND CONFIGURATION.....	27
5.1	INTRODUCTION.....	27
5.2	SOFTWARE DOWNLOADS.....	27
5.3	DRIVERS	27
5.4	DATASET/FIRMWARE PROGRAMMING	27
5.4.1	<i>Validator Manager</i>	27
5.4.1.1	General Description	27
5.4.1.2	System Requirements	27
5.4.1.3	Hardware Setup.....	28
5.4.1.4	Switching to Programming Mode (SSP).....	28
5.4.1.5	Programming the device	28
5.4.2	<i>Updating using a Micro SD card</i>	29
5.5	MICRO SD CARD LOGGING.....	30
6	ROUTINE MAINTENANCE.....	31
6.1	INTRODUCTION	31
6.2	CLEANING THE NV9 SPECTRAL.....	31
6.2.1	<i>Recommended cleaning intervals</i>	31
6.2.2	<i>Cleaning the validator</i>	31
6.2.2.1	Housing assembly cleaning.....	31
6.2.3	<i>Lozenge removal and cleaning</i>	32
6.2.4	<i>Lozenge fitting</i>	33
7	PROTOCOLS AND INTERFACING.....	35
7.1	INTRODUCTION.....	35
7.2	SSP AND ESSP.....	35
7.2.1	<i>General Description</i>	35
7.2.2	<i>Pin Assignments</i>	36
7.2.3	<i>Setup Examples</i>	37
7.2.3.1	Direct USB cable	37
7.2.3.2	IF17 Set up.....	37
7.3	CC4.....	39
7.3.1	<i>General Description</i>	39
7.3.2	<i>ccTalk® DES Encryption</i>	39
7.3.3	<i>Pinout</i>	40
7.3.4	<i>Setup Example Drawing/s</i>	41
7.3.4.1	Direct UBS Cable	41
7.3.4.2	IF17 Set up.....	41
7.4	CC2.....	42
7.4.1	<i>General Description</i>	42
7.4.2	<i>ccTalk® DES Encryption</i>	42
7.4.3	<i>Pinout</i>	43
7.4.4	<i>Setup Example Drawing/s</i>	44
7.4.4.1	Direct UBS Cable	44
7.4.4.2	IF17 Set up.....	44
8	FIRST LEVEL SUPPORT.....	45
8.1	BEZEL LED FLASH CODES	45
8.2	BEZEL/STATUS LED FLASH CODES	45
8.2.1	<i>NV9 Spectral Bezel Fault codes</i>	45
8.2.2	<i>Multi Notefloat Status LED Flash codes</i>	46



NV9 Spectral Range Manual

[<< Back to Contents](#)

Operational Flash codes	46
Normal Operation	46
LED State.....	46
Status.....	46
Error flash codes.....	46
Long.....	46
Flashes.....	46
Error	46
8.3 FREQUENTLY ASKED QUESTIONS	47
9 SECOND LEVEL SUPPORT	48
9.1 FAULT FINDING	48
9.1.1 Notes not accepted.....	48
9.1.2 All notes rejected.....	49
9.1.3 Notes accepted with no credits given	49
9.1.4 Acceptor runs slowly or continues to run	50
10 APPENDIX	51
10.1 CABLE DRAWINGS.....	51
10.1.1 CN214.....	51
10.1.2 CN174.....	52
10.1.3 CN392.....	53
10.1.4 WR02128.....	54



1 DOCUMENT INTRODUCTION

1.1 Related Documents

This document should be read together with the following:

For SSP/eSSP:

[Protocol Manual – SSP \(GA138\): SSP Interface Protocol Specification for integration](#)

[eSSP Implementation Guide \(GA973\): Information for programmers and integrators](#)

For Software:

[Software Manual – GA02037 Software Guide](#)

1.2 Manual Amendments

Rev.	Date	Amendment Details	Issued by
0.1	28/06/2018	First draft	AA
1.0	12/04/2019	First issue	JS
1.1	26/04/2019	Removed duplicate section	JS

1.3 Copyright

This manual set is Copyright © Innovative Technology Ltd. 2019. No part of this publication may be reproduced in any form or by any means used to make any derivative such as translation, transformation, or adaptation without permission from Innovative Technology Ltd. The contents of this manual set may be subject to change without prior notice.



1.4 Limited Warranty

Innovative Technology Ltd warrants each of its hardware products to be free from defects in workmanship and materials under normal use and service for a period commencing on the date of purchase from Innovative Technology Ltd or its Authorized Reseller, and extending for the length of time stipulated by Innovative Technology Ltd.

A list of Innovative Technology Ltd offices can be found in every section of this manual set. If the product proves defective within the applicable warranty period, Innovative Technology Ltd will repair or replace the product. Innovative Technology Ltd shall have the sole discretion whether to repair or replace, and any replacement product supplied may be new or reconditioned.

The foregoing warranties and remedies are exclusive and are in lieu of all other warranties, expressed or implied, either in fact or by operation of law, statutory or otherwise, including warranties of merchantability and fitness for a purpose.

Innovative Technology Ltd shall not be liable under this warranty if it's testing and examination disclose that the alleged defect in the product does not exist or was caused by the customer's or any third person's misuse, neglect, improper installation or testing, unauthorized attempts to repair, or any other cause beyond the range of the intended use. In no event will Innovative Technology Ltd be liable for any damages, including loss of profits, cost of cover or other incidental, consequential or indirect damages arising out the installation, maintenance, use, performance, failure or interruption of an Innovative Technology Ltd product, however caused.

1.5 Product Safety Information

Throughout this user manual, attention should be drawn to key safety points when using or maintaining the product.

These safety points will be highlighted in a box, like this:

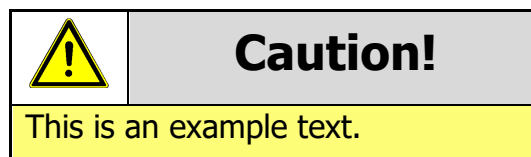

This user manual and the information it contains is only applicable to the model stated on the front cover, and must not be used with any other make or model.



Safety Notice! Read before using this product!

Safety Notice - Warning. Ensure power is removed before allowing access to the inside of this product. Ensure any static build up is discharged before allowing access to any part of this product or media contained. Always earth this product/base plate in accordance with the manual.

For use only in or with complete equipment where the acceptability of the combination is determined by UL LLC. When installed in an end-product, consideration must be given to the following:

- The power supply terminals and/or connectors are: Not investigated for field wiring
- The investigated Pollution Degree is: 2
- The following end-product enclosures are required: Mechanical, Fire

Sicherheitshinweis – Warnung: Es muss sichergestellt werden, dass das Gerät von der Versorgungsspannung getrennt wird, bevor ein Eingriff in das Innere des Gerätes erfolgt. Es muss sichergestellt werden, dass jegliche statische Aufladung des Gerätes entladen wird, bevor auf das Gerät oder auf innerhalb des Gerätes befindliche Objekte zugegriffen wird. Die Erdung des Gerätes muss immer gemäß Handbuch erfolgen.

Nur für die Verwendung in oder mit kompletter Ausstattung, dessen Eignung und Kombination von der UL LLC ermittelt wurde. Bei der Installation in einem Endprodukt, muss folgendes berücksichtigt werden:

- Die Spannungsversorgungsklemmen und/oder Verbinder sind: Feldverkabelung wurde nicht untersucht
- Der untersuchte Verschmutzungsgrad ist: 2
- Folgende Anforderungen an die Gehäuse des Endproduktes sind gefordert: Mechanisch, Feuer

Aviso de seguridad: Asegúrese de que la alimentación está desconectada y de que toda la energía estática es descargada antes de manipular este producto. Conecte a tierra la chapa base de la manera que se indica en el manual.

Solo para uso con dispositivos con los cuales la compatibilidad ha sido certificada por UL LLC. Tras su instalación en producto acabado, tener en cuenta lo siguiente:

- Los conectores y terminales de alimentación son: No se ha investigado/especificado cableado externo.
- El grado de contaminación determinado es: 2
- Los siguientes manuales/certificados de producto final son requeridos: Mecánico, Fuego

Avis de sécurité : Assurez-vous que l'alimentation est coupée et que toute l'énergie statique est déchargé avant de manipuler ce produit. Connecter à la terre, la plaque de base à la manière indiquée dans le manuel.

A utiliser Seulement avec les dispositifs dont la compatibilité a été certifiée par UL LLC. Après son installation dans le produit fini, prendre en considération ce qui suit:-

- Les connecteurs et les bornes d'alimentation sont : cela n'a pas été étudié/spécifié câblage externe.
- Le degré de contamination déterminé est: 2
- Les manuels suivants / les certificats du produit final sont nécessaires : mécanique, incendie

Bezpečnostní upozornění. Před manipulací uvnitř tohoto produktu se ujistěte, že je produkt odpojen od zdroje elektrického napětí. Ujistěte se, že jakýkoliv elektrostatický náboj byl vybit před manipulací s jakoukoliv částí tohoto produktu nebo obsaženým médiem. Vždy uzemněte tento produkt/základovou desku v souladu s návodem.

Pouze pro použití v nebo s kompletním vybavením, kde je přijatelnost kombinace určena UL LLC. Při instalaci v konečném produktu je třeba zvážit následující:

- Napájecí svorky a/nebo konektory: Nejsou sledované pro externí kabeláž
- Sledovaný stupeň znečištění je: 2
- Následující krytí konečného produktu jsou požadované: Mechanické, Protipožární



2 PRODUCT INTRODUCTION

2.1 General Description

The NV9 Spectral is a highly secure and technologically advanced banknote validator, offering casino level security at a mid-range price. State of the art spectral sensors provide high resolution imaging, scanning 1.28 million data points to authenticate the validity of notes. This versatile banknote validator can be mounted horizontally or vertically, with cashbox and bezel options to suit all applications and a micro SD card for data logging.

2.2 Key Features

- High resolution imaging
- Full note high resolution imaging – 1.28 million data points
- Micro SD card slot for data logging
- Faster note to note processing
- Suitable for Global Applications
- Exceptional note handling
- Optical and mechanical anti-strimming technology
- Stained note detection
- Modular design
 - Add on multi note recycler available (NV22)

2.3 Typical Applications

- Amusement
- Vending

2.4 Component Overview

2.4.1 NV9 Spectral (NV9S)

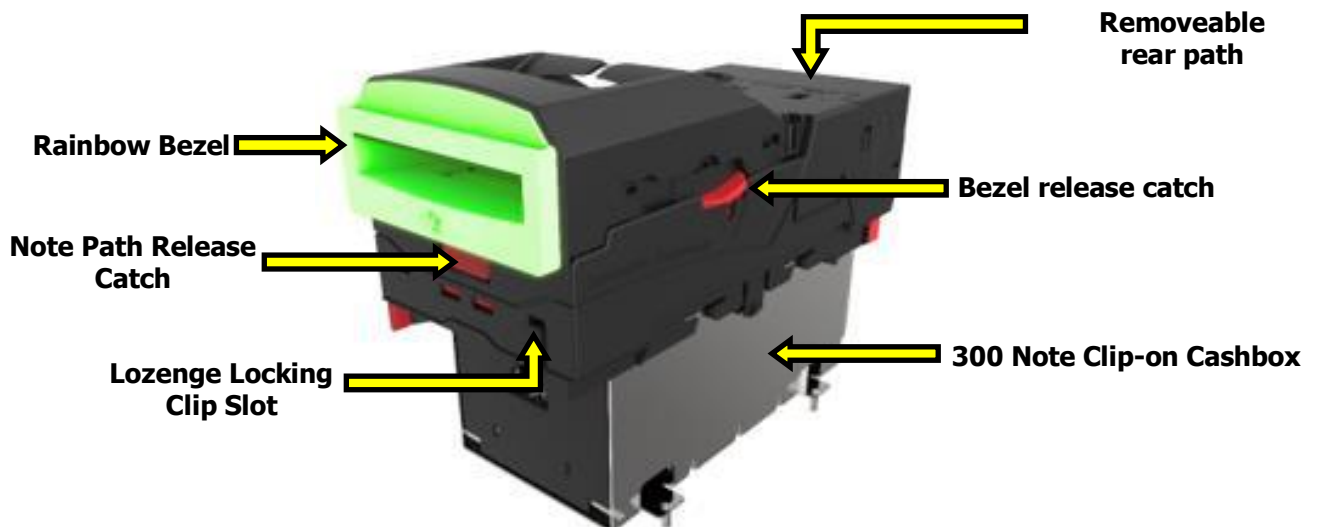

2.4.2 NV22

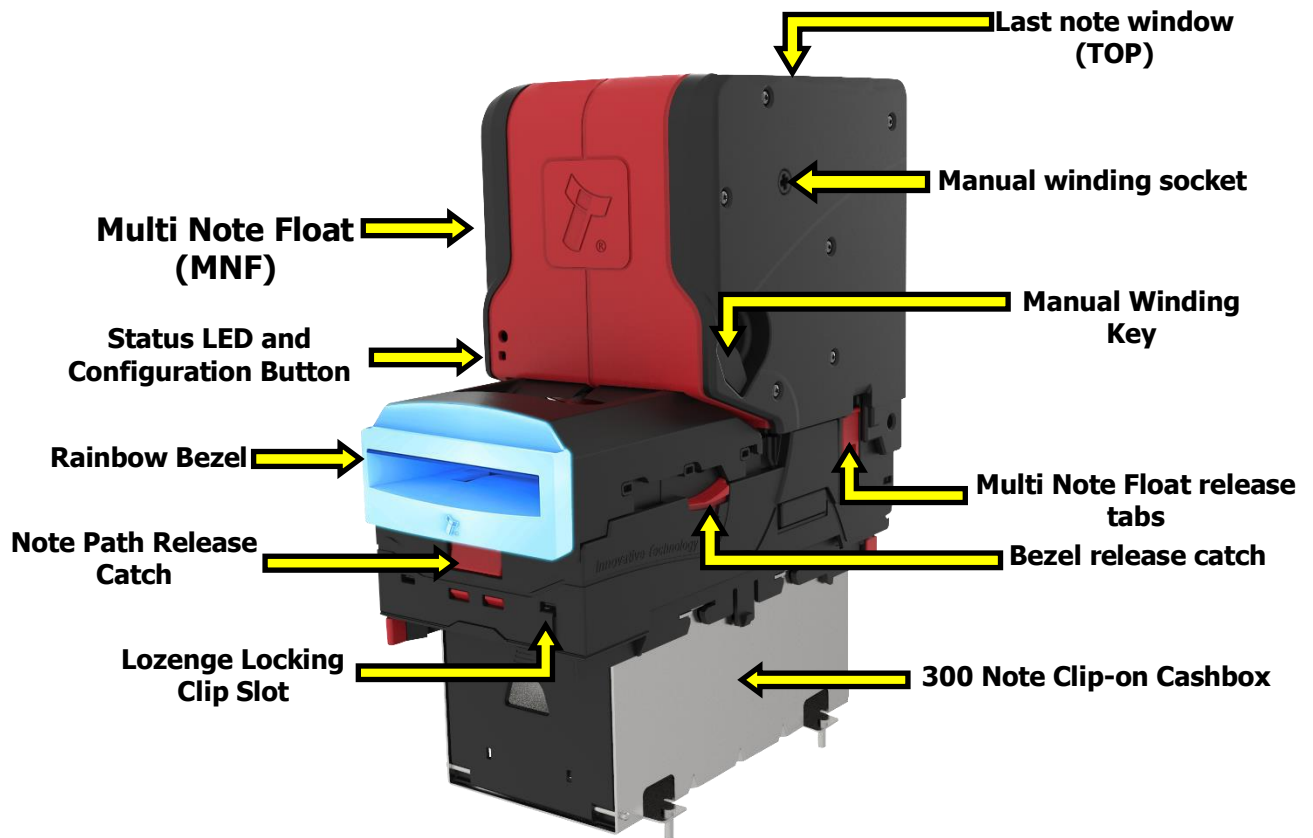

2.4.3 Interface Connectors

The NV9 Spectral makes use of a 16-pin socket connector to interface the NV9S to the host machine. The 16-pin socket is located within the housing assembly, the upper housing assembly will need to be opened before accessing the connector. To access the interface connector, push the release catch and lift the upper housing assembly.

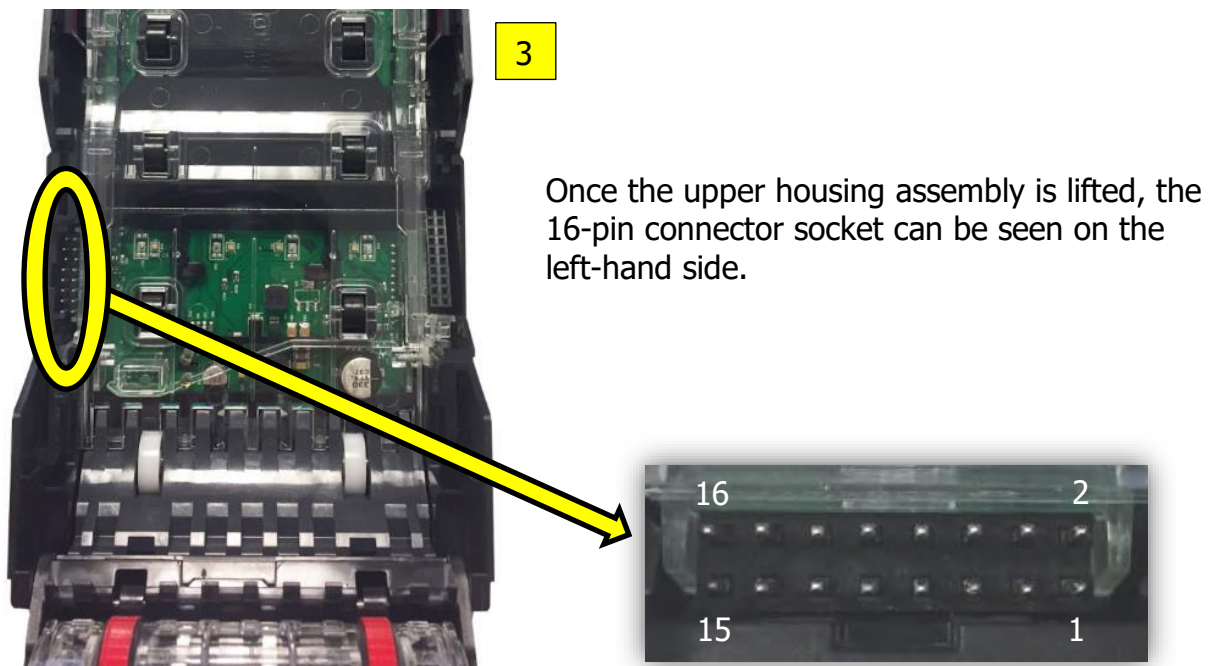
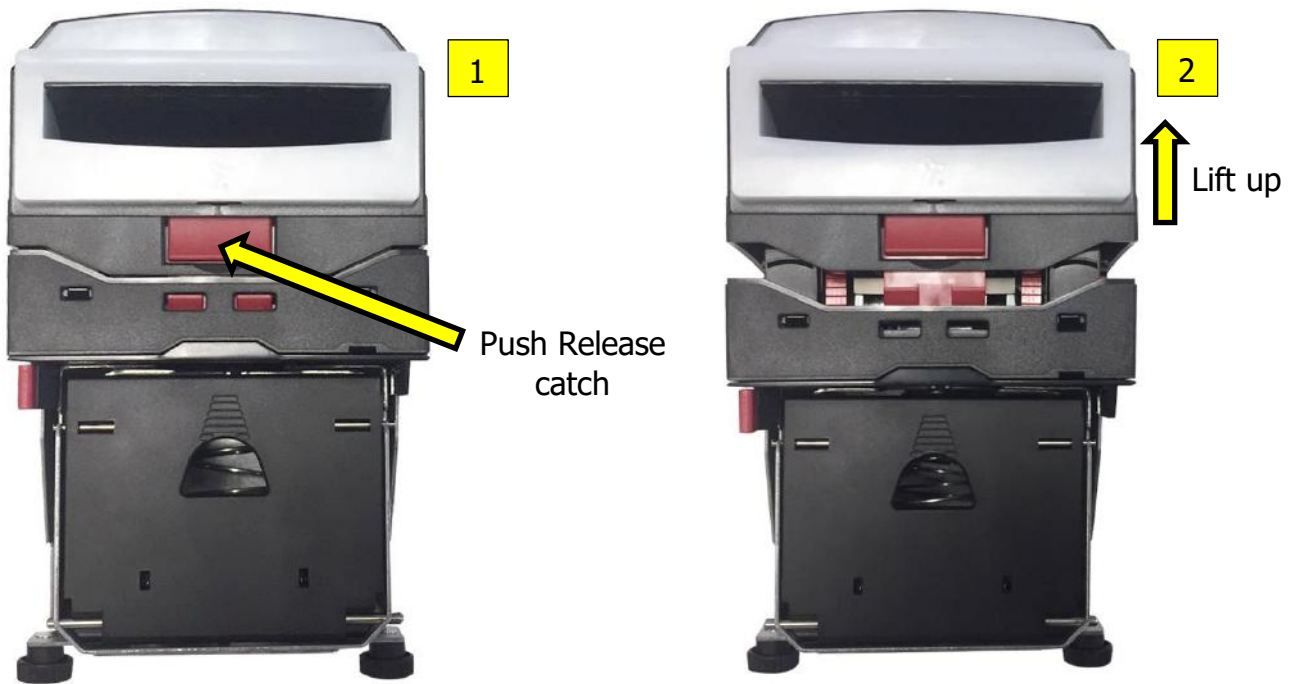

NV9 Spectral Range Manual

[<< Back to Contents](#)

The pin numbering of the socket is shown below:

Information

Power is required regardless of connection type.

Pin	Description
1	Serial Data Out (Tx)
5	Serial Data In (Rx)
11	USB Data +
12	USB Data -
13	USB Power (+5V)
15	+ V
16	0V / Ground Connection

Power is always required on pins 15 and 16 of the 16-way connector.

The NV9 Spectral has a second connector which is an 8-way socket which is used in conjunction with the rainbow bezel, refer to section [10.1.4](#) for the cable drawing (WR02128).

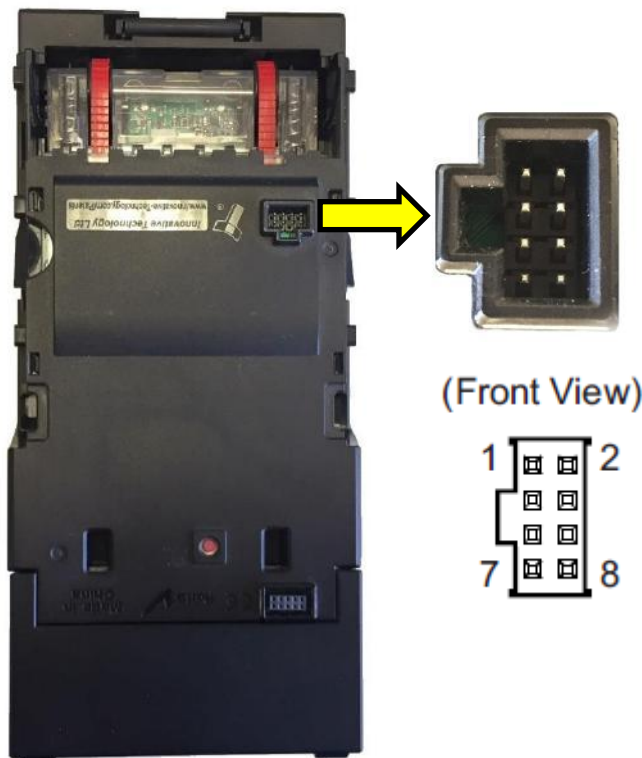

Information

Currently the Horizontal Rainbow Bezel is only implemented.

Pin	Description
1	Vend 3
2	Vend 4
3	Inhibit 3
5	Busy
7	VCC
8	GND



2.4.4 Configuration Button Functionality

The configuration button has multiple functions, see section below. The common function of the configuration button is to switch the protocol to SSP, commonly known as programming mode.



Once the Multi Notefloat is attached the configuration button on the NV9 Spectral is not accessible, Use the configuration button on the front of the Multi Notefloat.

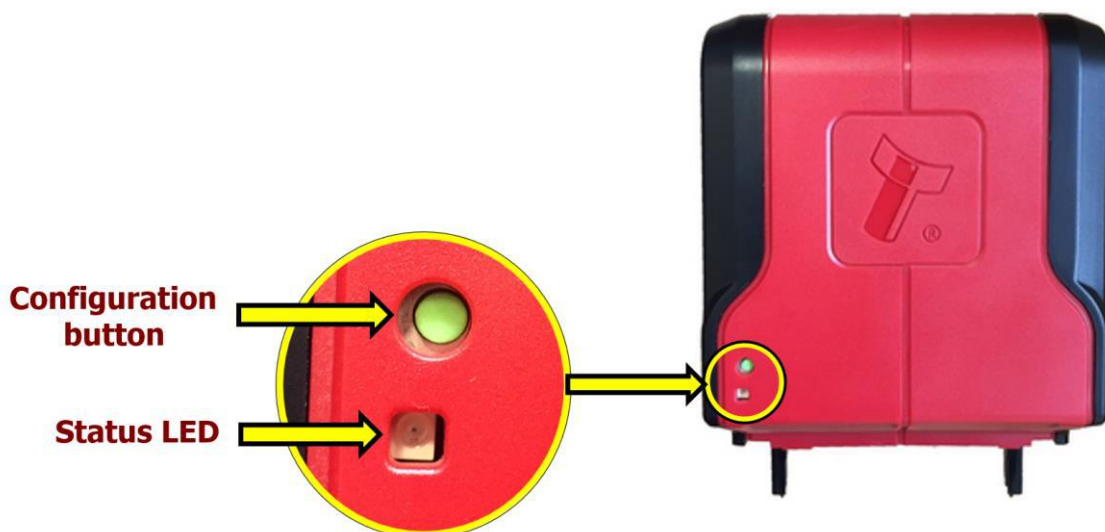

2.4.4.1 Configuration Button Press Functions

Action	Power status	Function
Press and hold (more than 3 seconds) until the bezel illuminates, then release	Powered ON	Sets validator to SSP commonly known as programming mode
Press twice (within half a second)	Powered ON	Shows current interface type (see flash count table below)
Press and hold as validator is powered up	Powered OFF / ON	Resets to factory settings
Release front catch and open pathway and apply power, then press and hold (more than 3 seconds) until red LED lights up front right.	Powered OFF / ON	DES Trusted Mode

2.4.4.2 Bezel Interface Flash Counts

The NV9 Spectral Validator leaves the factory pre-set to at least one currency and one interface so that it is ready for immediate installation. The dataset and interface used are shown on the label fixed to the top of the upper housing assembly.

Flash Count	Interface
1	SSP
6	CC4/ CC2

 **Information**

CcTalk/CC4, CC2 and SSP are currently implemented

NV9 Spectral Range Manual

[<< Back to Contents](#)

2.4.5 Bezel Options

ITL Part Number	Description	Details
PA00189	NV9 USB Standard Bezel (82mm)	http://innovative-technology.com/shop/bezels/nv9-standard-horizontal-bezel-detail
PA00190	NV9 USB Vertical Up Snout Bezel(82mm)	http://innovative-technology.com/shop/bezels/nv9-vertical-up-snout-bezel-detail
PA00188	NV9 USB Vertical Up Bezel (82mm)	http://innovative-technology.com/shop/bezels/nv9-vertical-up-snout-bezel-detail
PA00191	NV9 USB Vertical Down Snout Bezel (82mm)	http://innovative-technology.com/shop/bezels/nv9-vertical-down-snout-bezel-detail
PA03280	NV9 Spectral Horizontal Rainbow Bezel (82mm)	https://innovative-technology.com/shop/bezels/nv9-usb-rainbow-bezel-detail

2.4.6 Cashbox Options

ITL Part Number	Description	Details
PA00185	NV9 USB 300 Clip On Cashbox	http://www.innovative-technology.com/shop/bezels/nv9-300-clip-on-cashbox-detail
PA00186	NV9 USB 300 Lockable Cashbox	http://www.innovative-technology.com/shop/bezels/nv9-300-lockable-cashbox-detail
PA00192	NV9 USB 300 Slide Cashbox	http://www.innovative-technology.com/shop/bezels/nv9-300-slide-cashbox-detail
PA00193	NV9 USB 600 Clip On Cashbox	https://innovative-technology.com/shop/bezels/nv9-600-clip-on-cashbox-detail
PA00194	NV9 USB 600 Slide In Cashbox	https://innovative-technology.com/shop/bezels/nv9-600-slide-in-cashbox-detail



3 TECHNICAL DATA

3.1 Dimensions

Note: If required, IGES 3D models are available on request from Innovative Technology technical support; support@innovative-technology.com

3.1.1 NV9 Spectral Dimensions

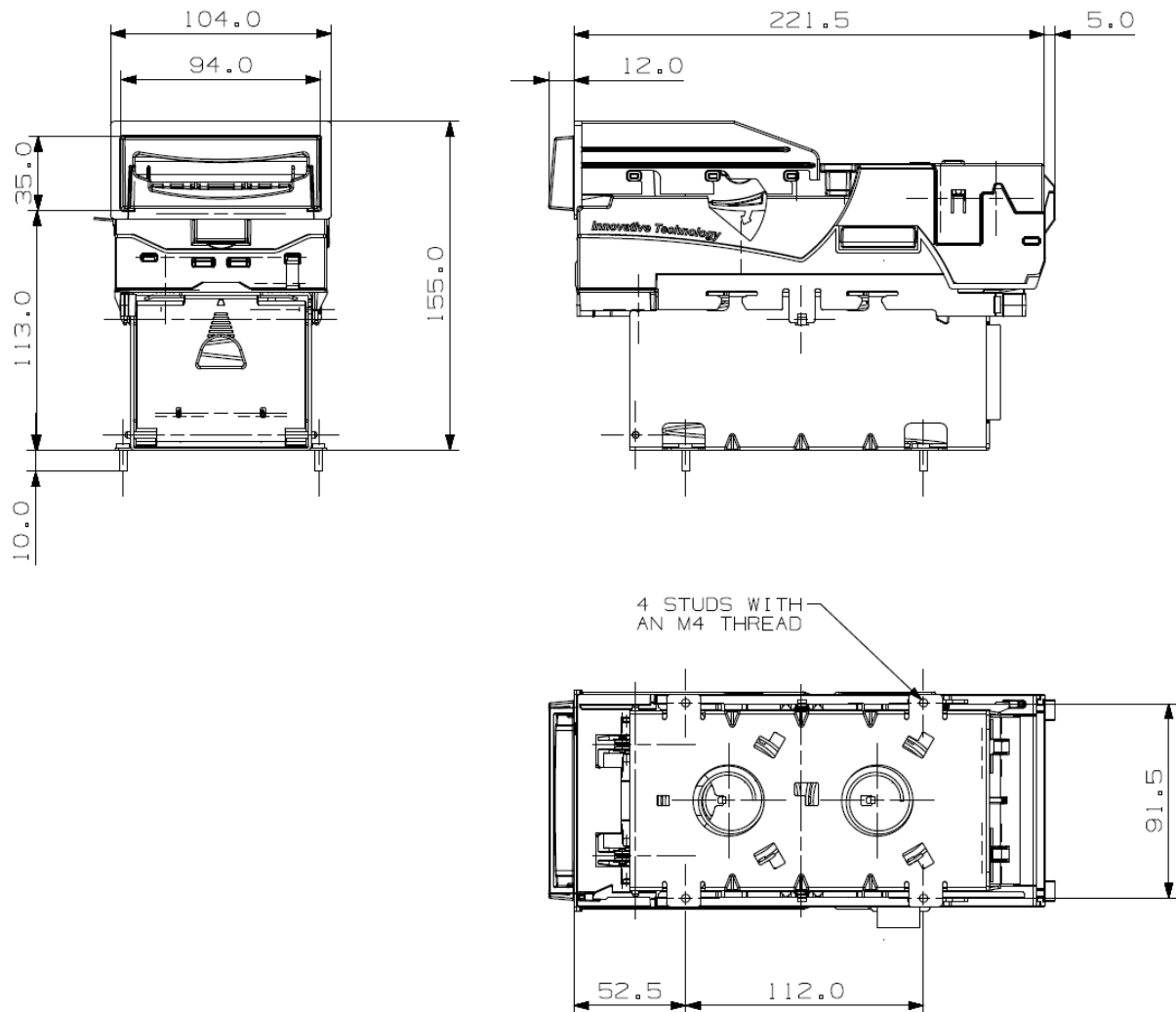

NV9 Spectral Range Manual

[<< Back to Contents](#)

3.1.2 NV22 Dimensions

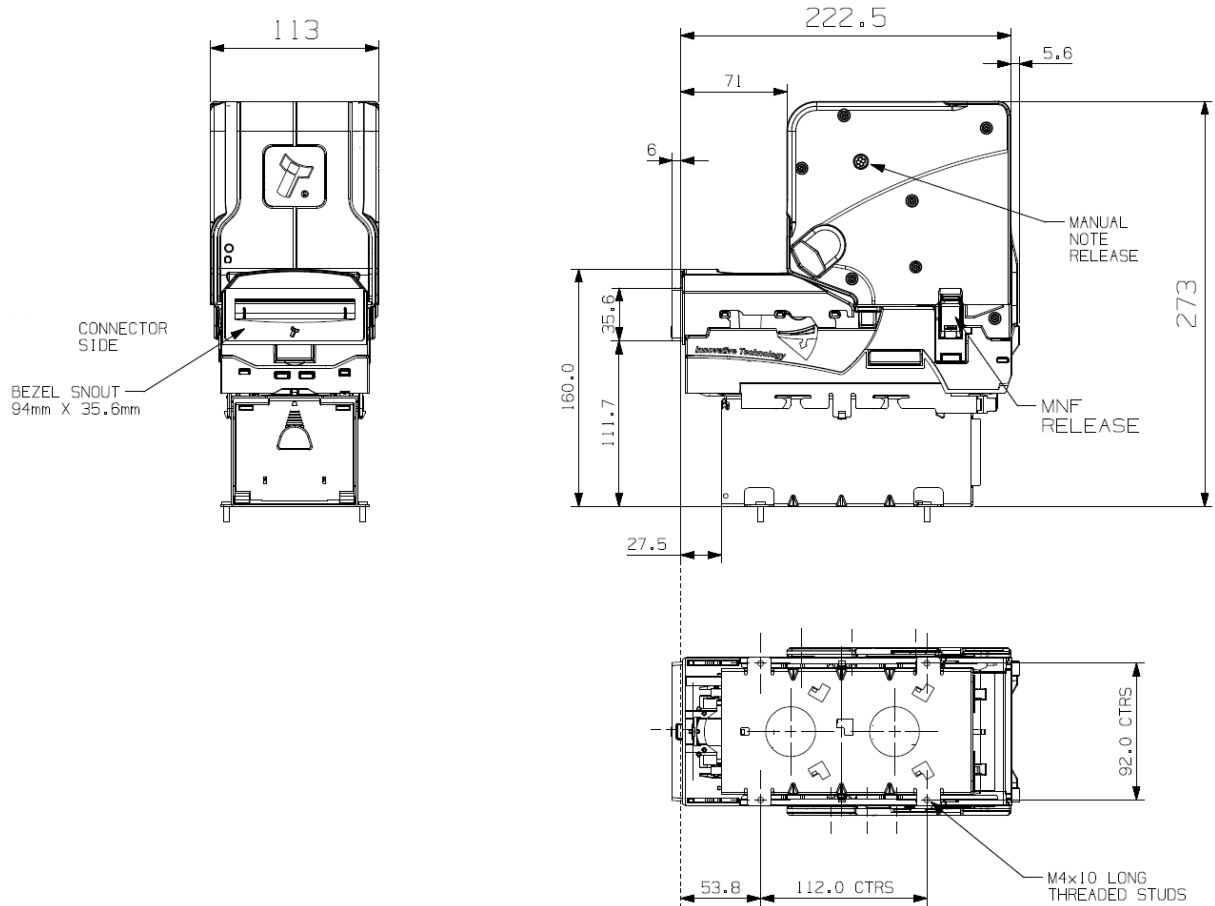

3.2 Weight (without notes)

- Validator = 1.05 KG
- Bezel (standard) = 0.10 KG
- Cashbox (slide on) = 0.57 KG
- Combined = 1.72 KG
- Multi Notefloat = 1.2 KG
- NV22 (NV9 Spectral & Multi Notefloat) = 2.92 KG

3.3 Environmental Requirements

Environment	Minimum	Maximum
Temperature	+5°C / 37.4°F	+50°C / 122°F
Humidity	5%	95% Non-condensing



NV9 Spectral Range Manual

[<< Back to Contents](#)

3.4 Power Requirements

3.4.1 Supply Voltages

Supply Voltage	Minimum	Nominal	Maximum
Supply Voltage (V DC)	+ 10.8 V DC	+ 12 V DC	+ 13.2 DC
Supply Ripple Voltage	0 V	0 V	0.25 V @ 100 Hz

3.4.2 Supply Currents

Phase of operation	Current draw (max)
Standby	200mA
Running (RMS)	1 A
Peak	3 A

3.4.3 Power Supply Guidance

The NV9 Spectral requires a stable 12 V DC / 3 A power supply. Check the power requirements of the host machine and other peripherals to dimension a suitable power environment for the machine setup.

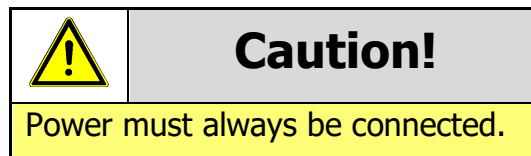

TDK Lambda manufactures suitable power supplies. See table below for further details.

Power Supply Unit	Specification	RS Stock Code	Farnell Stock Code
TDK Lambda RWS-50B-12	+12 V DC / 4.3 A	839-9626	2452725
TDK Lambda LS75-12	+12 V DC / 6 A	680-2773	1657444

3.5 Interface Logic Levels

Interface Logic Levels	Logic Low	Logic High
Inputs	0V to +0.5V	+3.7V to +12V
Outputs with 2K2Ω pull-up resistor	+0.6V	Pull-up voltage of host interface
Maximum Current Sink	50mA per Output	



[<< Back to Contents](#)

3.6 Reliability Data

The below data refers to the Mean Cycles Between Failure (MCBF) and the Mean Cycles Between Intervention (MCBI). The difference between the two is that a failure would usually require the unit being replaced. Whereas an intervention would be an issue that is easily clearable such as a reset or clearing a note path jam.

A cycle is classed as a note or ticket being either accepted or dispensed. For example; if a unit accepts a note and then dispenses a note as change, it is classed as two cycles.

NV9 Spectral

MCBF: 200,000 Cycles

MCBI: 100,000 Cycles

It is important to note that when adding a recycler or printer, you are doubling the number of modules. Thus, the MCBF/MCBI will naturally be halved.

NV22

MCBF: 100,000 Cycles

MCBI: 50,000 Cycles

3.7 Media Requirements

3.7.1 Notes

	Minimum	Maximum
Length	90mm	170mm
Width	62mm	82mm

The NV9S range supports multiple currencies and denominations as per the specifications detailed in the table above. Furthermore polymer and windowed notes are in use in a number of countries and so are already fully supported on the NV9S range of validators.



4 MECHANICAL INSTALLATION

4.1 Compatibility

4.1.1 Hardware Compatibility

4.1.1.1 Machine mounting

The NV9 Spectral may be used as fitting replacement for the following products:

- NV9USB

The NV22 may be used as fitting replacement for the following products:

- NV11

Innovative Technology Ltd. has a policy of continuous product improvement. Due to design changes older model or product bezels (and cashboxes) may not be compatible with the NV9 Spectral. However, new product deliveries always include a bezel (and cashbox) that must be used.

4.1.1.2 Machine interfacing

By design the NV9 Spectral/ NV22 is pin to pin compatible with the NV9/NV11 series validators.

4.1.1.3 Power Supply

It is vital that the NV9 Spectral is connected to a power supply being able to provide the required power environment. A weak power supply causes malfunctioning of the NV9 Spectral such like note rejects or missing credits. If the NV9 Spectral is used as a fitting replacement for an older model or product it is recommended to check the power supply specifications of the machine. The power supply of the machine might be designed for the older model or product but not suitable for the NV9 Spectral. The NV9 Spectral might have higher power consumption. Refer to section [3.4](#) for full power requirement details of the NV9 Spectral.

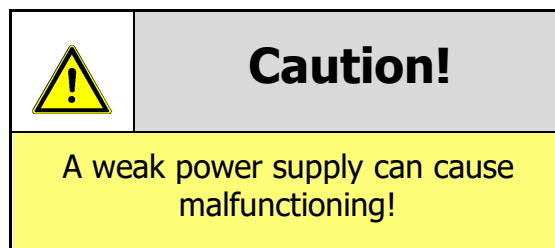

4.2 Software Compatibility

4.2.1.1 Interface protocols

When using the NV9 Spectral/ NV22 as a fitting replacement for an older model or product some events such like credits may be given earlier or later. This is due to improved firmware routines and faster motors being used. This may cause missing events such like credits in those host machines where timeouts are defined for the older model or product. Contact the machine manufacturer for full compatibility of the NV9 Spectral.

	Caution!
Timing issues may cause missing events such like credits!	

4.2.2 Re-programming

For re-programming the NV9 Spectral use the latest version of Validator Manager. For further details on Re-programming the NV9 Spectral refer to section [5.4](#).

	Caution!
Older versions of Validator Manager may not support the NV9 Spectral!	

4.3 Bezel Mounting

4.3.1 Bezel Removal

1. Bezel release catch

The bezel is removed by pushing the red bezel latches on both sides of the validator downwards, and sliding the bezel forwards away from the bezel latches. ensure the bezel has slid forward enough to clear the steep part of the latch.

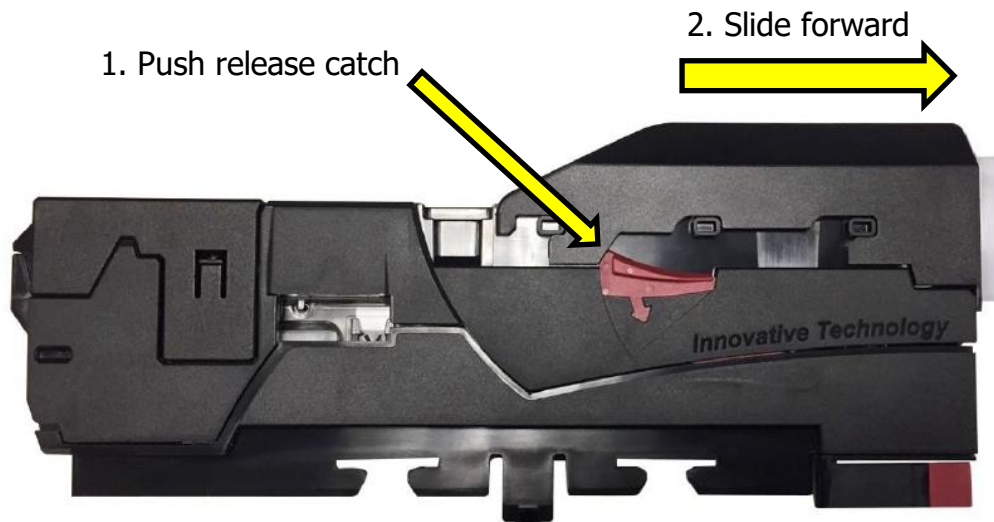

2. Dislocating the bezel from locating pins

Lift the bezel upwards once it has been slid forward and is clear of the locating pins, the process should not be forceful.

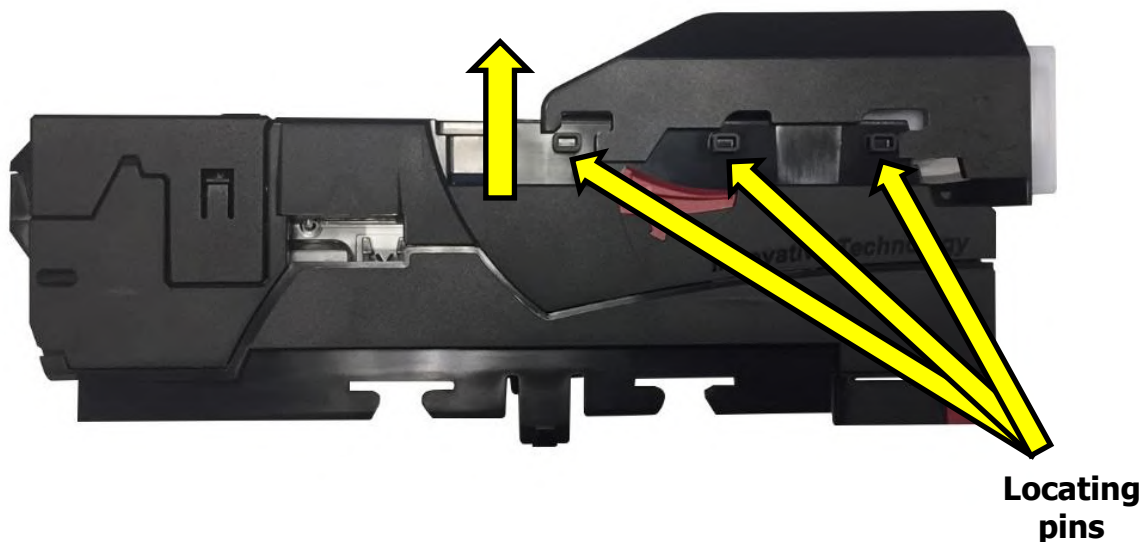

4.3.2 Bezel Fitting (Standard Bezel)

1. Positioning the bezel for fitting

When fitting the bezel onto the validator ensure that the bezel sits in place ready to be interlocked with the locating pins on the housing assembly.

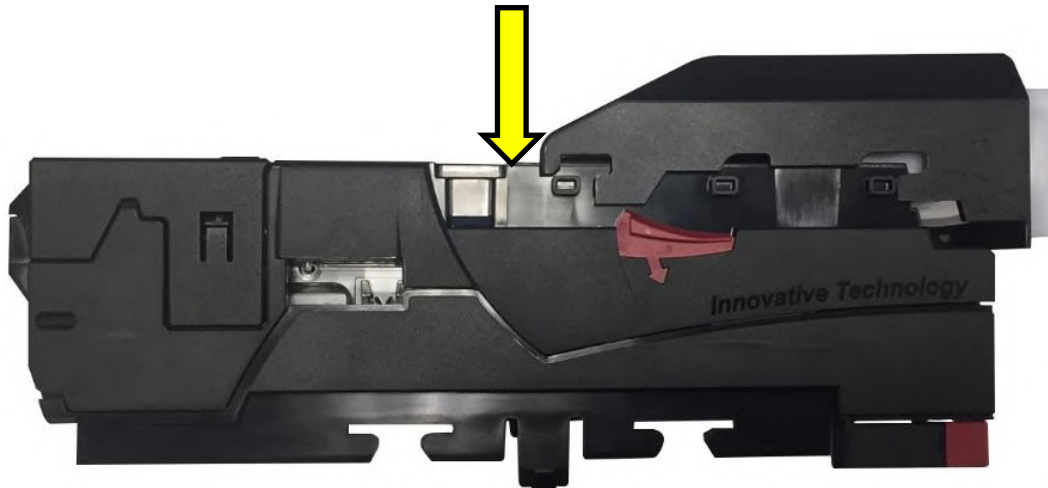

2. Sliding the bezel into place

Once the bezel is in place with respect to the locating pins, slide the Bezel back until it clicks into place. ensure that both sides have clicked into place.



WARNING!

Ensure bezel is secured to the validator

Slide back



4.4 Cashbox Mounting

4.4.1 Cashbox Removal

To remove the cashbox, push the release catch away from the unit and pull the cashbox backwards.

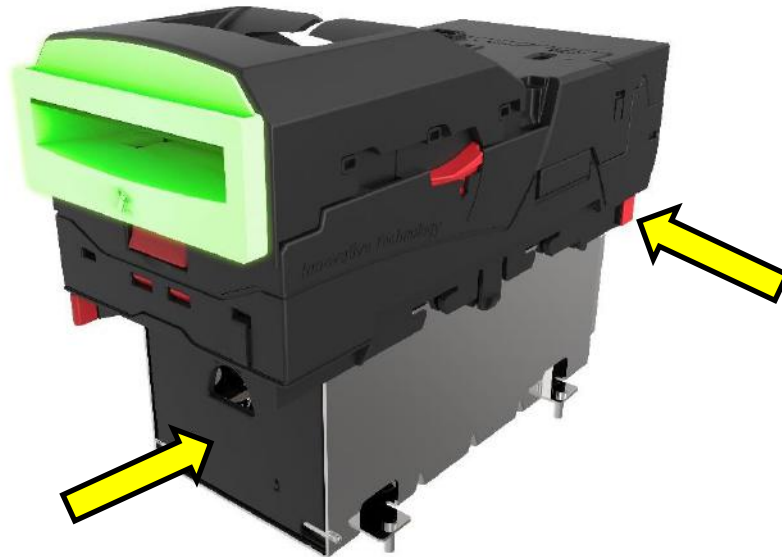

4.4.2 Cashbox fitting (slide on cashbox)

1. Positioning the cashbox for fitting

Firstly, ensure the cashbox hooks are aligned with the accommodating grooves on the main housing assembly. Thereafter push the cashbox hooks into place.

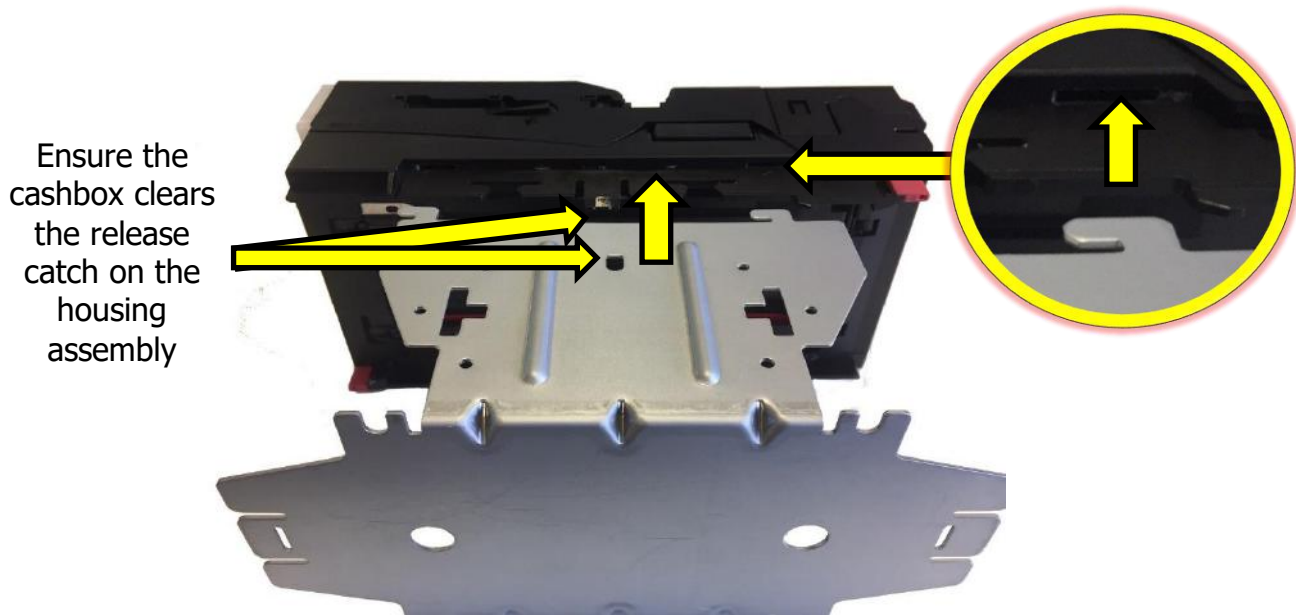

2. Sliding the cashbox into place

Ensure the cashbox hooks are aligned and inserted into the accommodating grooves on the under-housing assembly.

4.5 Removing the Blanking Plate

1. Opening NV9 Spectral

Before removing the blanking plate, the validator head will need to be opened, push the release catch and lift the validator head.

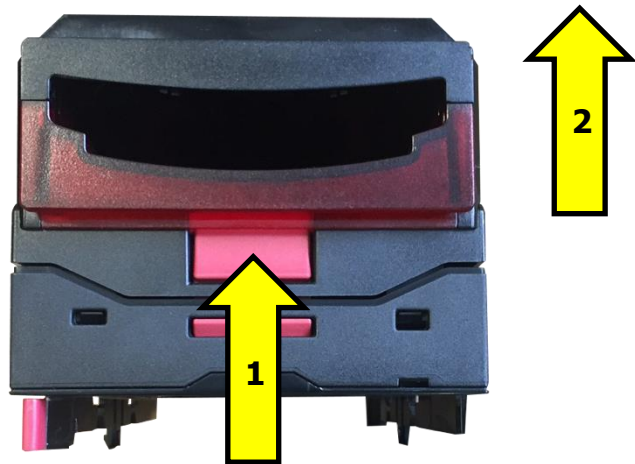

2. Latch Release

Pull the release catch on each side.

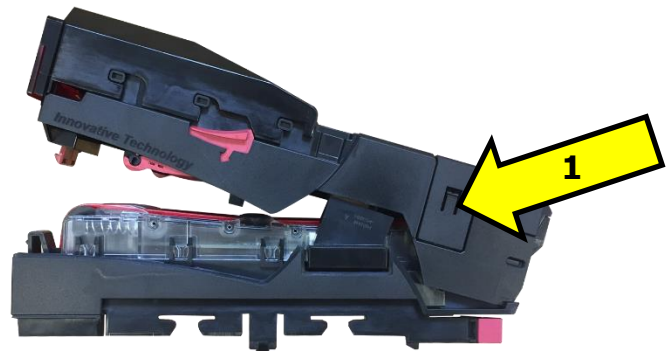

3. Lift Blanking Plate

With latches release lift the blanking plate

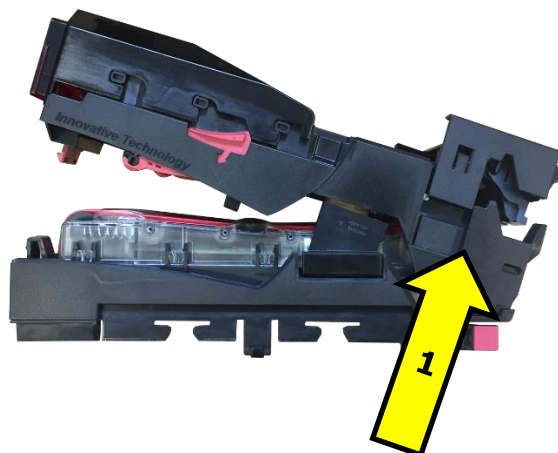

4.6 Mounting Multi Notefloat

1. Removing blanking plate

If the blanking plate has not already been removed follow [4.5 Removing the Blanking Plate](#)



2. Positioning Multi Notefloat

Make sure the MNF is aligned with NV9S at the highlighted position and slide the MNF in to position. Make sure the MNF's locking tabs are open to make it easier to fit.

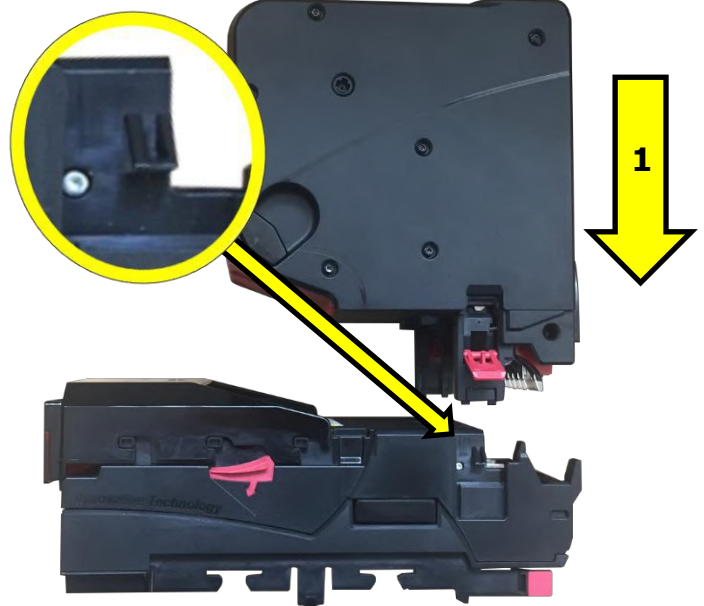

3. Locking Tabs

To Finish fitted the MNF close the locking tabs on both sides.

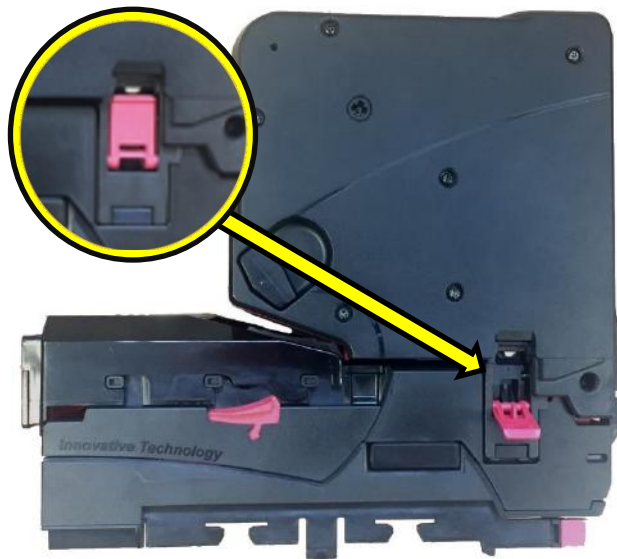

[<< Back to Contents](#)

4.7 Removing Multi Notefloat

1. Locking Tabs

Undo locking tabs on both sides.

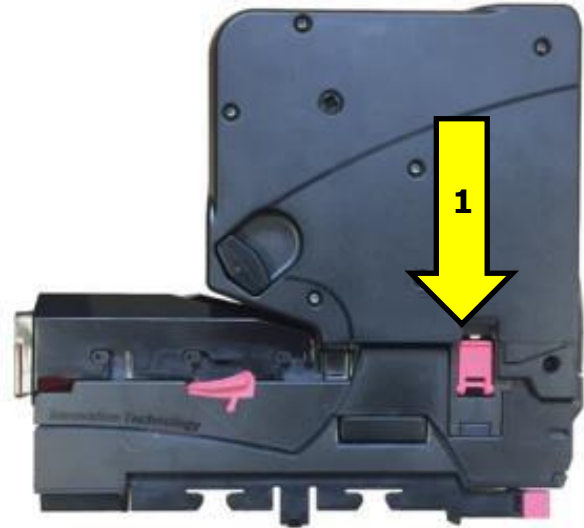

2. Lift MNF

Remove the MNF lifting the MNF of the NV9S.

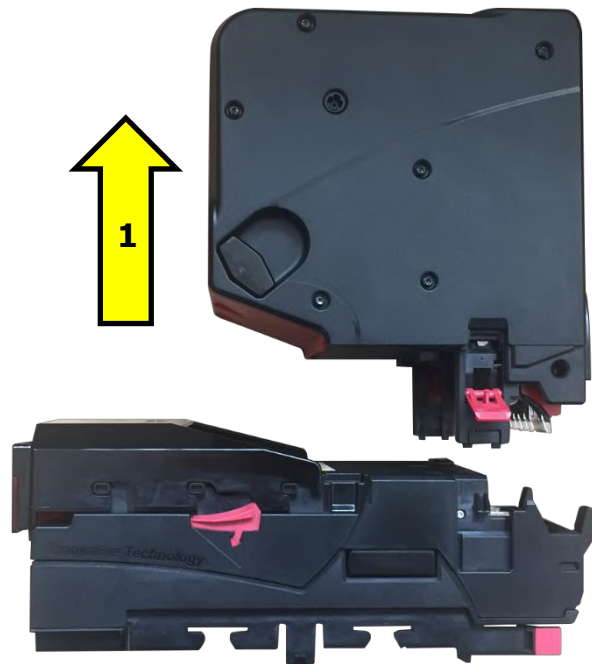

5 SOFTWARE INSTALLATION AND CONFIGURATION

5.1 Introduction

The NV9 Spectral range leaves the factory pre-programmed with the latest dataset and firmware files. However, it is important to ensure that the device is kept up to date with the latest dataset and firmware. This section will provide a brief overview of the various update possibilities with the NV9 Spectral. For detailed instructions refer to the relevant manual package supplied with the software or contact support@innovative-technology.com.

5.2 Software Downloads

All software from Innovative Technology Ltd is free of charge and can be downloaded from the website www.innovative-technology.com/support/secure-download once registered and logged in. If not registered, create an account via the Create an account form. A confirmation email will be sent to the registered email address once all contact details have been successfully submitted.

5.3 Drivers

The ITL drivers allow the validators to connect to a compatible Windows device. If connecting via an IF17 then this process will not need to be followed as the drivers are signed Microsoft Drivers and should install automatically. If this isn't the case or the Computer/Laptop is disconnected from the network, there is a standalone package included within the driver downloads.

5.4 Dataset/Firmware Programming

5.4.1 Validator Manager

5.4.1.1 General Description

Validator Manager is a utility which allows the user to reprogram any of ITL's products. Note that admin rights are required during installation. The validator must be in SSP for the Validator Manager to detect the device. Contact ITL Support for a pre-release.

5.4.1.2 System Requirements

- Windows XP SP3 or above
- .Net Framework 4
- 256mb ram
- 50mb hard disk free
- Connected NV9S/NV22 with active com port

	Caution!
There have been instances where one of the dll's (itdata1.dll) used in Validator Manager are flagged as a Trojan, this is a false positive and if this occurs, a rule will need to be added to the antivirus on the PC or Laptop	



NV9 Spectral Range Manual

[<< Back to Contents](#)

5.4.1.3 Hardware Setup

Connect the power supply to the DA2/IF17. Connect one side of the A to B USB cable to the DA2/IF17 and the other end to the computer or laptop.

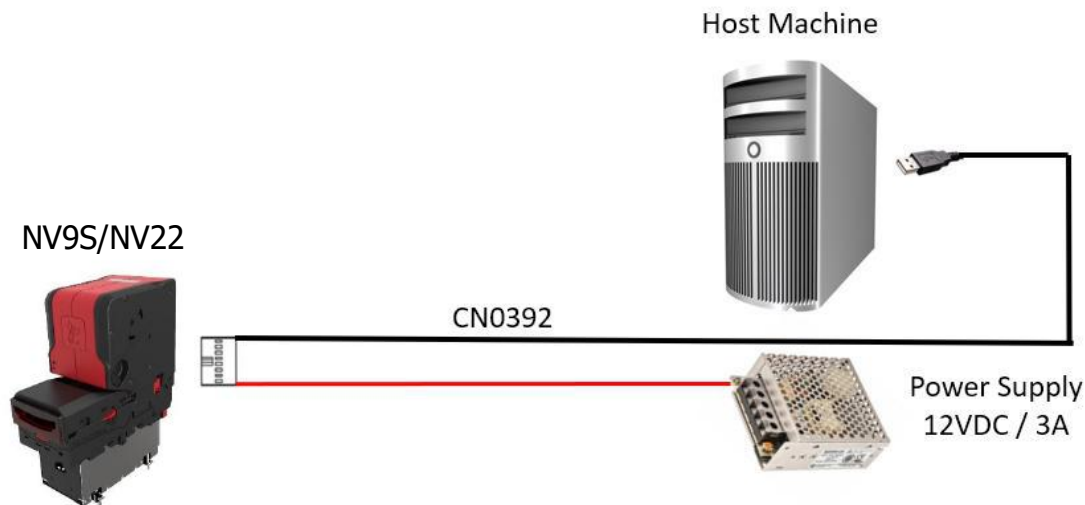

5.4.1.4 Switching to Programming Mode (SSP)

Before programming via validator Manager, the NV9S/NV22 needs to be switched to its programming mode (SSP interface). Refer to [2.4.4](#) for the procedure for doing this.

5.4.1.5 Programming the device

Once the unit has been switched to SSP, open Validator Manager and click detect devices. This will scan all active com ports for a unit, if the NV22 fails to connect, ensure the correct drivers are installed and the unit is in SSP.

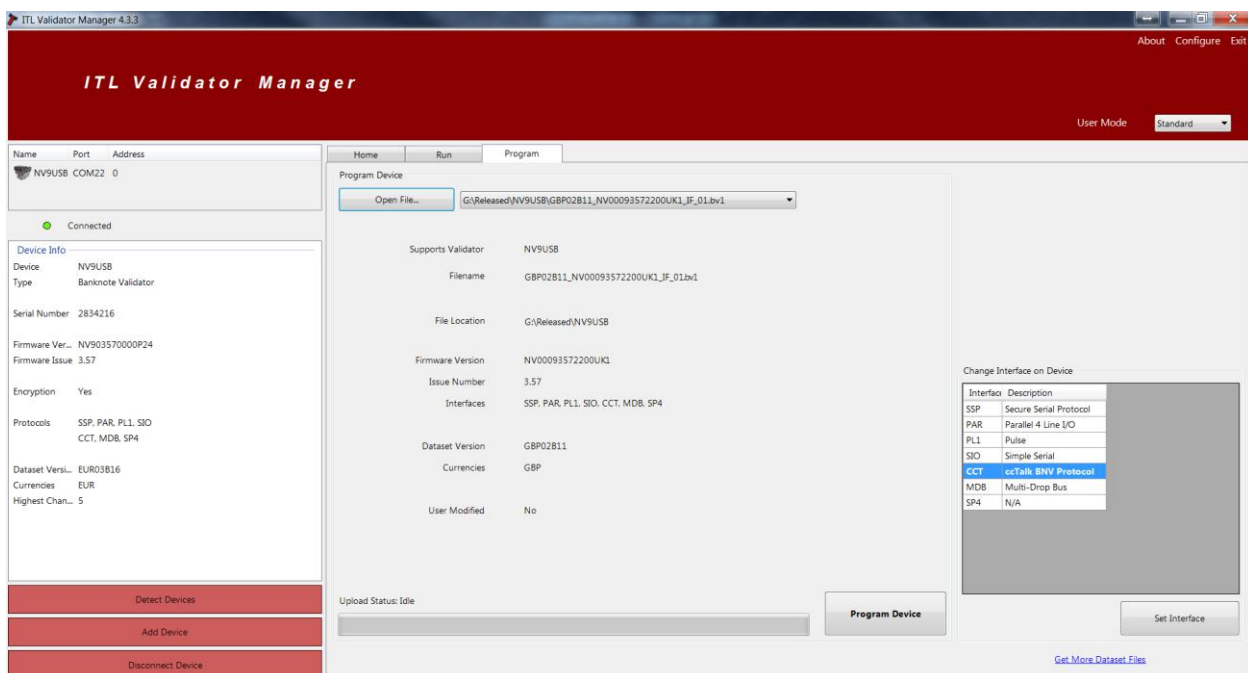

By selecting the Program tab, the NV22 can be reprogrammed. To begin the upload, click open file, then browse to the file location (usually Downloads) before clicking OK.

Once the file has been selected its information will be populated and the Program device tab will become active. thereafter hit 'Program Device', the unit's bezel will now begin to flash signaling the update has begun.

	Caution!
Interrupting the download process can result in the unit entering a non-functional state, once the process has started it cannot be halted.	

When completed the unit will restart and a pop-up box will appear saying Device Programming Complete.

5.4.2 Updating using a Micro SD card

Currently the way adopted in updating NV9 Spectral via the micro SD is the following, the firmware file needs to be amended to **NV9S.bv1** and will need to be placed into the micro SD card root folder. Once the SD card is placed into its accommodating slot, the update will commence once the NV9 Spectral has been power cycled (like the NV200S update recovery), the bezel will flash when updating and then go solid upon completion. Standard update will be developed in the future.

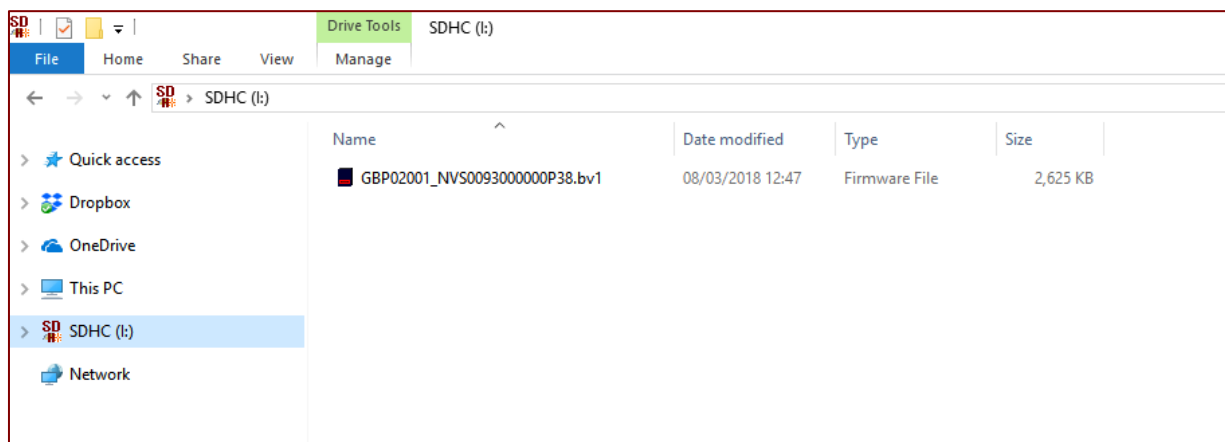

5.5 Micro SD card logging

The NV9S range takes advantage of a micro SD card for data logging (minimum of a class 4 SD card and larger the card the more logs can be created class 10 recommend). The micro SD card slot can be found on the exterior side of the housing assembly after the bezel has been removed (refer to section 4.3), see image below. Ensure there are three files present before inserting the SD card into the slot, the three files are as follows, **hsdata**, **nv9sl**, **valaudit**.



Below is a screenshot showing the file structure needed for data logging, the files need to be created in the **root directory** of the micro SD card which is the first or top-most **directory** in a hierarchy. It can be likened to the trunk of a tree, as the starting point where all branches originate from.

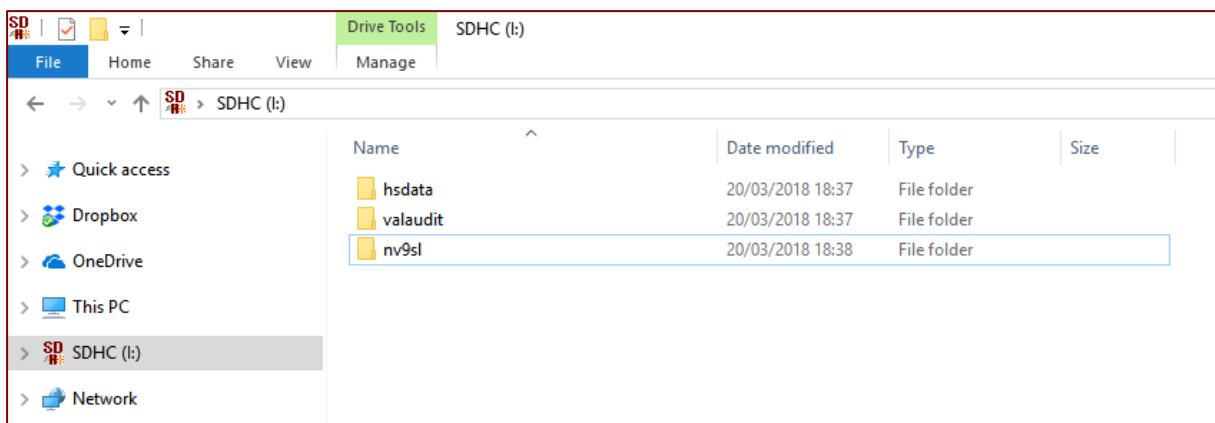

6 ROUTINE MAINTENANCE

6.1 Introduction

Depending upon the environment the NV9 Spectral is running in it may require cleaning, belt changing or note path clearing more frequently.

6.2 Cleaning the NV9 Spectral

Disconnect the power **BEFORE** carrying out any cleaning operations to avoid the risk of causing damage to the validator.

6.2.1 Recommended cleaning intervals

Clean the optical lenses every 6 months or more if the unit is in a particularly harsh environment. Dirt, dust or other residue leads to bad note acceptance and other performance degradation. Refer to section [5.2.2](#) for comprehensive cleaning instructions.

6.2.2 Cleaning the validator



WARNING!

Do not use solvent based cleaners such as alcohol, Petrol, methylated spirits, white spirit or PCB cleaner

Do not use solvent based cleaners such as alcohol, petrol, methylated spirits, white spirit or PCB cleaner. Using these solvents can cause permanent damage to the units; only use a mild detergent solution as directed below.

6.2.2.1 Housing assembly cleaning

The upper housing assembly contains vital sensors for required for optimum operation of the validator, dirt can obscure the light paths which can lead to failure in sensing the note, therefore upper housing assembly should be cleaned using a lint free cloth.

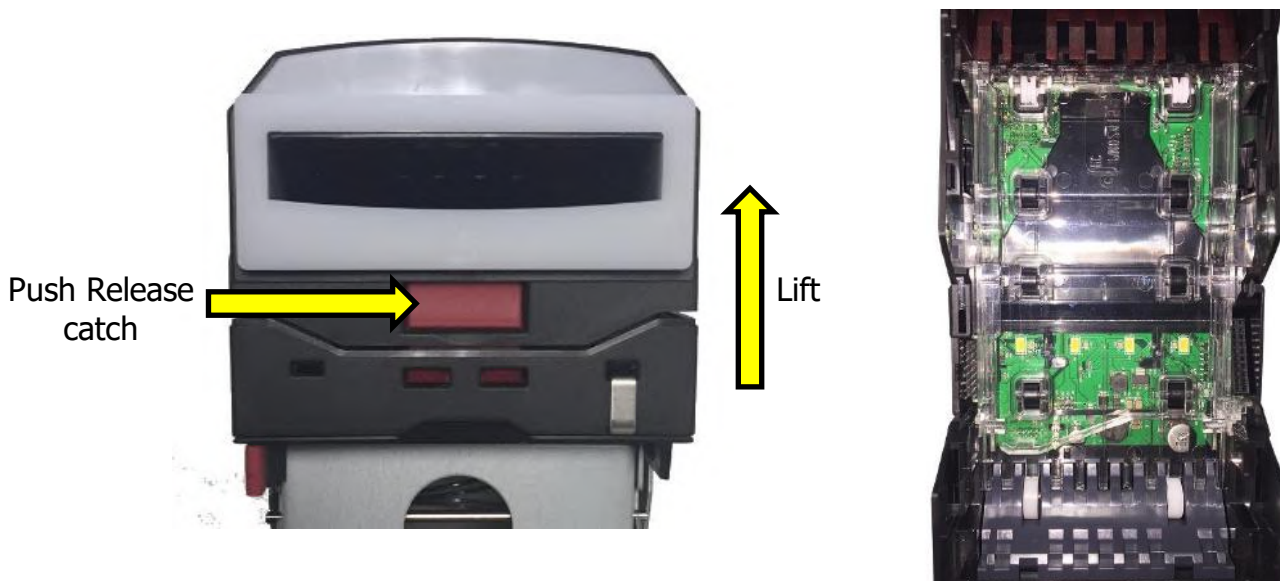

6.2.3 Lozenge removal and cleaning

1. Locking clip removal

The lozenge is secured into place via a locking clip. To remove the lozenge the locking clip must be removed. Ensure that the cashbox has been removed initially to gain access to the locking pin on the underside of the main housing assembly.



After the cashbox is removed the locking pin can be removed by lifting the locking pin upwards and pushing it towards the bezel.

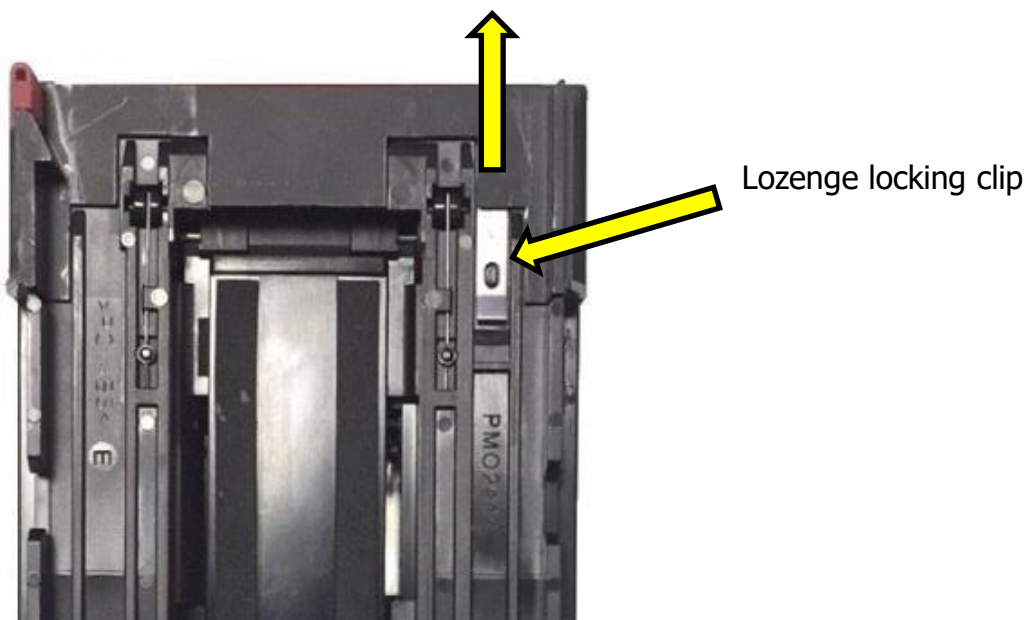

2. Detaching the lozenge from the housing assembly

The Lozenge assembly is secured into place via the latches attached to the lozenge. Pushing the lozenge latches forwards will release the Lozenge out of the housing assembly, then lift up the lozenge.

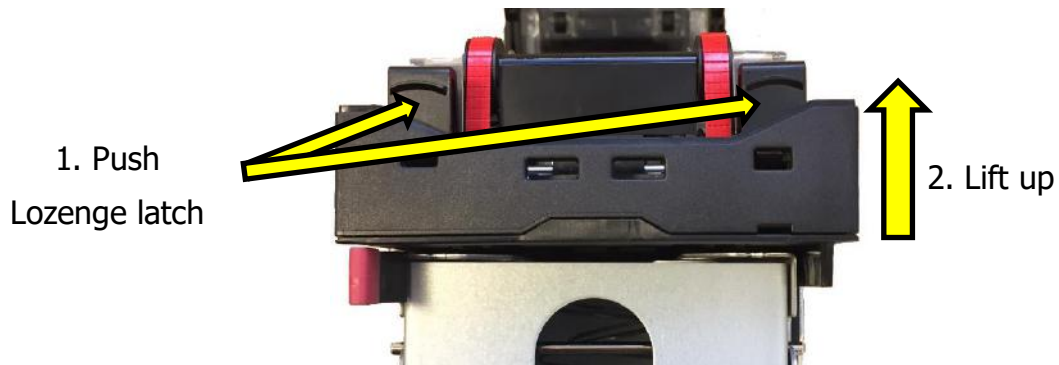

3. Cleaning the lozenge

A lint free cloth dampened with water and containing a mild detergent (such as dish detergent) can be used to clean the belts on the lozenge. ensure both the top and bottom parts of the lozenge are cleaned.

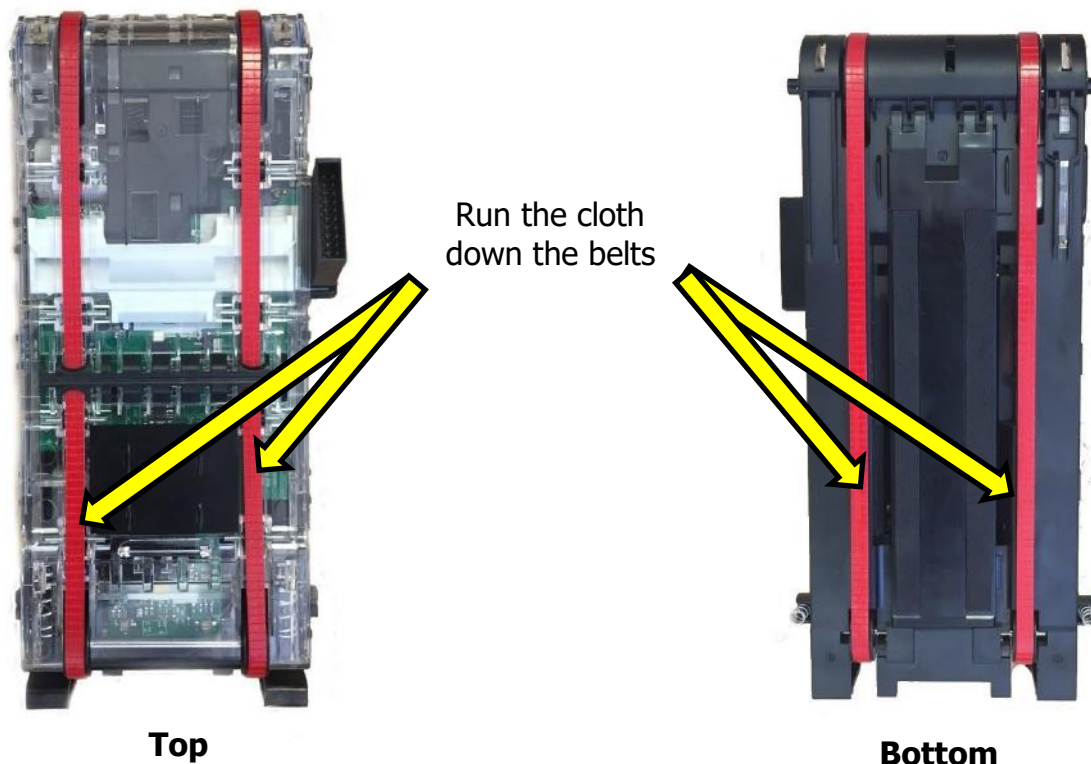

6.2.4 Lozenge fitting



[<< Back to Contents](#)

1. Placing the lozenge into place

When placing the lozenge back into the housing assembly, ensure that the lozenge is secured into the grooves of the rear side of the housing assembly, then push down the lozenge.



2. Clicking the lozenge into place

After the lozenge is in place, push the lozenge latches down to click into place. Ensure the lozenge is secured into grooves provided.



7 PROTOCOLS AND INTERFACING

7.1 Introduction

The NV9 Spectral supports standard industry protocols. Interfaces that are not listed may be available upon request. For any queries regarding interfaces that are not listed contact support@innovative-technology.com.

	Caution!
The use of an encrypted protocol (preferable eSSP) is strongly recommended to achieve the highest security!	

7.2 SSP and eSSP

7.2.1 General Description

Smiley[®] Secure Protocol (SSP) and Encrypted Smiley[®] Secure Protocol (eSSP) are field proven secure interfaces specifically designed by Innovative Technology Ltd. to address the problems by cash handling systems in gaming machines. Problems such as acceptor swapping, re-programming and line tapping are all addressed. This interface is recommended for all new designs. Innovative Technology Ltd. provides full SDK packages upon request including Interface Specification, Implementation Guide as well as source code examples.

7.2.2 Pin Assignments



Pin	Name	Type	Description
1	Vend 1	Output	Serial Data Out (Tx)
2	Vend 2	Output	DA3 Data Logging
3	Vend 3	Output	Not Used
4	Vend 4	Output	Not Used
5	Inhibit 1	Input	Serial Data In (Rx)
6	Inhibit 2	Input	Not Used
7	Inhibit 3	Input	Not Used
8	Inhibit 4	Input	Not Used
9	Busy	Output	Not Used
10	Escrow	Input	Not Used
11	USB +	Data	USB Data +
12	USB -	Data	USB Data -
13	USB Vcc	Power	USB Vcc (+5VDC)
14	Factory Use Only		Do not connect
15	+ Vin	Power	+12/24VDC Supply
16	0V	Power	0V Supply (GND)

	Caution!
+12VDC and 0V (GND) must always be connected, also when using USB connections.	

NV9 Spectral Range Manual

[<< Back to Contents](#)

7.2.3 Setup Examples

The drawings below highlight's how to connect the NV9 Spectral to an SSP or eSSP host machine using available cables and interfaces from Innovative Technology Ltd. For cable drawings refer to section [10.1](#).

7.2.3.1 Direct USB cable

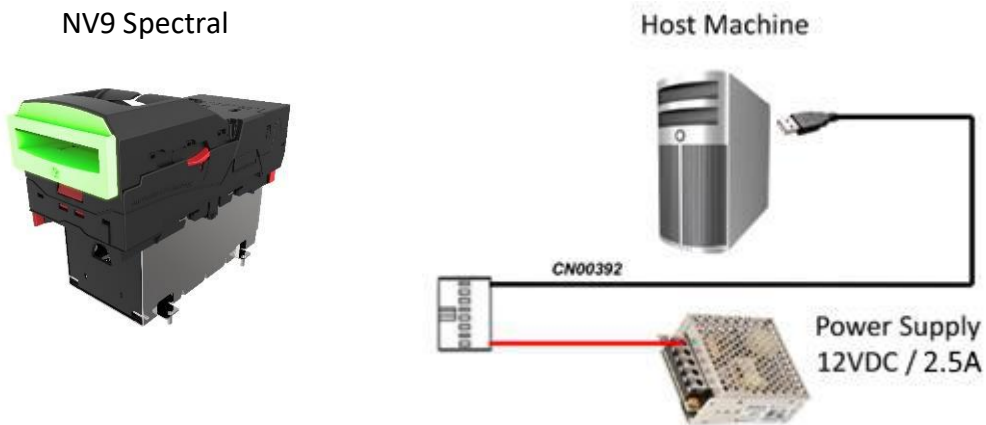

Type	ITL Part Number	Description	Details
Cable	CN00392	Validator to USB Cable	http://www.innovative-technology.com/de/shop/cables/nv9-nv10-usb-host-cable-detail

7.2.3.2 IF17 Set up

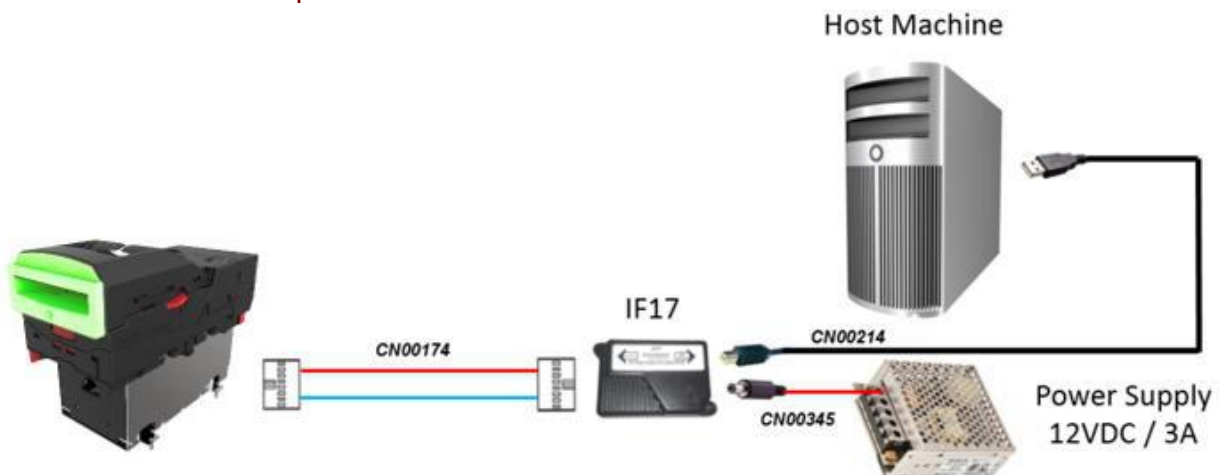

Type	ITL Part Number	Description	Details
------	-----------------	-------------	---------



NV9 Spectral Range Manual

[<< Back to Contents](#)

Cable	CN00174	NV9 / NV10 Ribbon Cable	http://innovative-technology.com/shop/cables/nv9-nv10-ribbon-cable-detail
Cable	CN00214	USB A to B cable assembly	http://innovative-technology.com/shop/cables/usb-a-to-b-cable-assembly-detail
Cable	CN00345	DA3 / IF17 / IF18 Power Cable	http://innovative-technology.com/shop/cables/da3-if17-if18-power-cable-detail
Interface	IF17	TTL to USB Converter	http://www.innovative-technology.com/shop/accessories/if17-interface-converter-detail



7.3 CC4

7.3.1 General Description

The CC4 protocol is an extension of ccTalk with additional status commands to support NV9 Spectral in ccTalk. Contact support for the necessary protocol documentation.

	Caution!
Innovative Technology Ltd. provides full SDK packages including Interface Specification, Implementation Guide as well as source code examples for SSP respectively eSSP only!	

7.3.2 ccTalk® DES Encryption

When using ccTalk® DES encryption, the NV9 Spectral and host machine must exchange a secret key which forms the basis of the communication encryption. This exchange is performed in a Trusted Mode maintaining security. The Trusted Mode can only be entered by a physical access to the NV9 Spectral.

7.3.3 Pinout

Below is an image of the 16-way connector, refer to section [2.4.1](#) which details how to gain access to the connector.



Pin	Name	Type	Description
1	Vend 1	Output	Serial Data (link to Pin 5)
2	Vend 2	Output	DA3 Data Logging
3	Vend 3	Output	Not Used
4	Vend 4	Output	Not Used
5	Inhibit 1	Input	Serial Data (link to Pin 1)
6	Inhibit 2	Input	Not Used
7	Inhibit 3	Input	Not Used
8	Inhibit 4	Input	Not Used
9	Busy	Output	Not Used
10	Escrow	Input	Not Used
11	USB +	Data	USB Data +
12	USB -	Data	USB Data -
13	USB Vcc	Power	USB Vcc (+5VDC)
14	Factory Use Only		Do not connect
15	+ Vin	Power	+12 VDC Supply
16	0V	Power	0V Supply (GND)

	Caution!
+12VDC and 0V (GND) must always be connected	

NV9 Spectral Range Manual

[<< Back to Contents](#)

7.3.4 Setup Example Drawing/s

The drawings below highlight's how to connect the NV9 Spectral to an SSP or eSSP host machine using available cables and interfaces from Innovative Technology Ltd. For cable drawings refer to section [10.1](#).

7.3.4.1 Direct UBS Cable

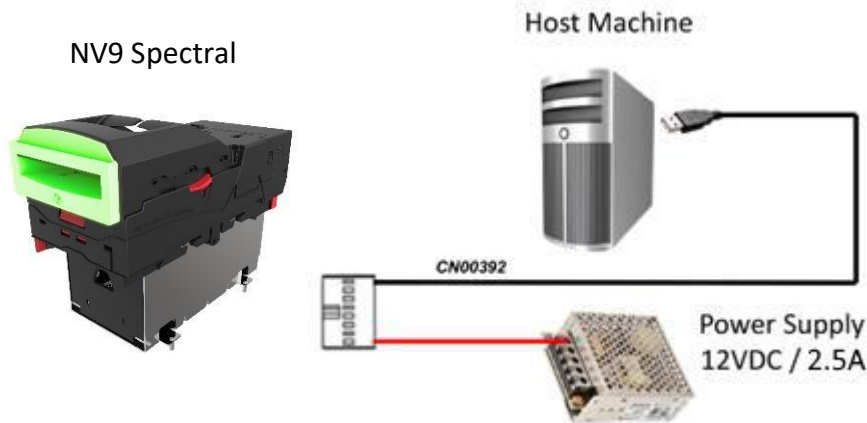

Type	ITL Part Number	Description	Details
Cable	CN00392	Validator to USB Cable	http://www.innovative-technology.com/de/shop/cables/nv9-nv10-usb-host-cable-detail

7.3.4.2 IF17 Set up

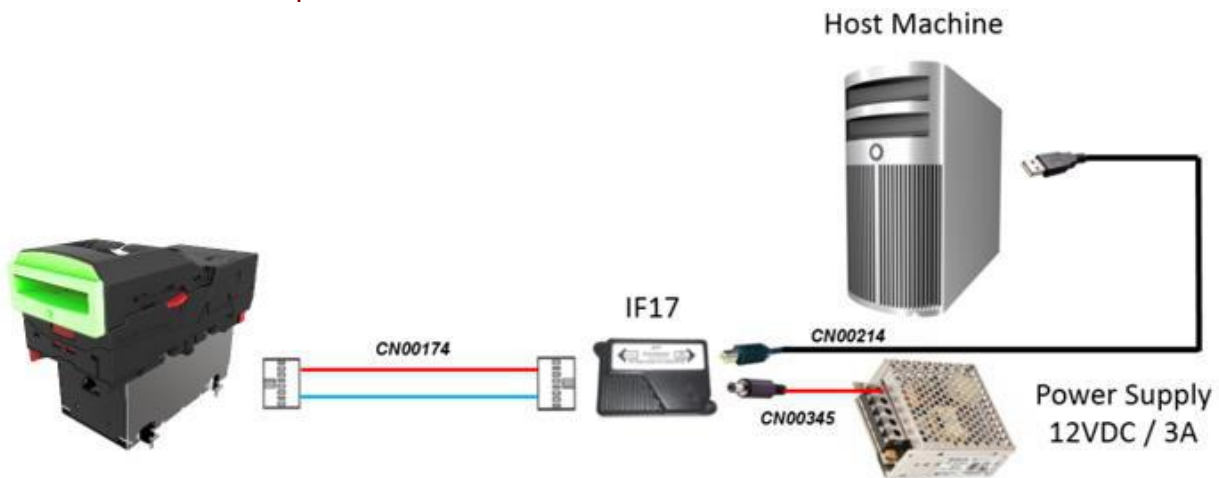

Type	ITL Part Number	Description	Details
Cable	CN00174	NV9 / NV10 Ribbon Cable	http://innovative-technology.com/shop/cables/nv9-nv10-ribbon-cable-detail
Cable	CN00214	USB A to B cable assembly	http://innovative-technology.com/shop/cables/usb-a-to-b-cable-assembly-detail
Cable	CN00345	DA3 / IF17 / IF18 Power Cable	http://innovative-technology.com/shop/cables/da3-if17-if18-power-cable-detail
Interface	IF17	TTL to USB Converter	http://www.innovative-technology.com/shop/accessories/if17-interface-converter-detail



7.4 CC2

7.4.1 General Description

The CC2 protocol is an extension of ccTalk with additional status and payout commands to support the Multi Notefloat recycler unit and thus should be used if wanting to use the NV22 in ccTalk. Contact support for the necessary protocol documentation.

	Caution!
Innovative Technology Ltd. provides full SDK packages including Interface Specification, Implementation Guide as well as source code examples for SSP respectively eSSP only!	

7.4.2 ccTalk® DES Encryption

When using ccTalk® DES encryption, the NV22 and host machine must exchange a secret key which forms the basis of the communication encryption. This exchange is performed in a Trusted Mode maintaining security. The Trusted Mode can only be entered by a physical access to the NV22.

7.4.3 Pinout

Below is an image of the 16-way connector, refer to section [2.4.1](#) which details how to gain access to the connector.



Pin	Name	Type	Description
1	Vend 1	Output	Serial Data (link to Pin 5)
2	Vend 2	Output	DA3 Data Logging
3	Vend 3	Output	Not Used
4	Vend 4	Output	Not Used
5	Inhibit 1	Input	Serial Data (link to Pin 1)
6	Inhibit 2	Input	Not Used
7	Inhibit 3	Input	Not Used
8	Inhibit 4	Input	Not Used
9	Busy	Output	Not Used
10	Escrow	Input	Not Used
11	USB +	Data	USB Data +
12	USB -	Data	USB Data -
13	USB Vcc	Power	USB Vcc (+5VDC)
14	Factory Use Only		Do not connect
15	+ Vin	Power	+12 VDC Supply
16	0V	Power	0V Supply (GND)

	Caution!
+12VDC and 0V (GND) must always be connected	

NV9 Spectral Range Manual

[<< Back to Contents](#)

7.4.4 Setup Example Drawing/s

The drawings below highlight's how to connect the NV9 Spectral to an SSP or eSSP host machine using available cables and interfaces from Innovative Technology Ltd. For cable drawings refer to section [10.1](#).

7.4.4.1 Direct UBS Cable

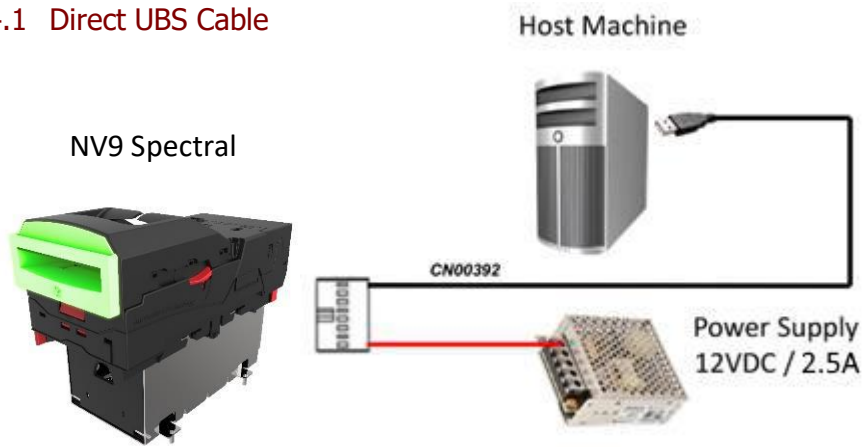

Type	ITL Part Number	Description	Details
Cable	CN00392	Validator to USB Cable	http://www.innovative-technology.com/de/shop/cables/nv9-nv10-usb-host-cable-detail

7.4.4.2 IF17 Set up

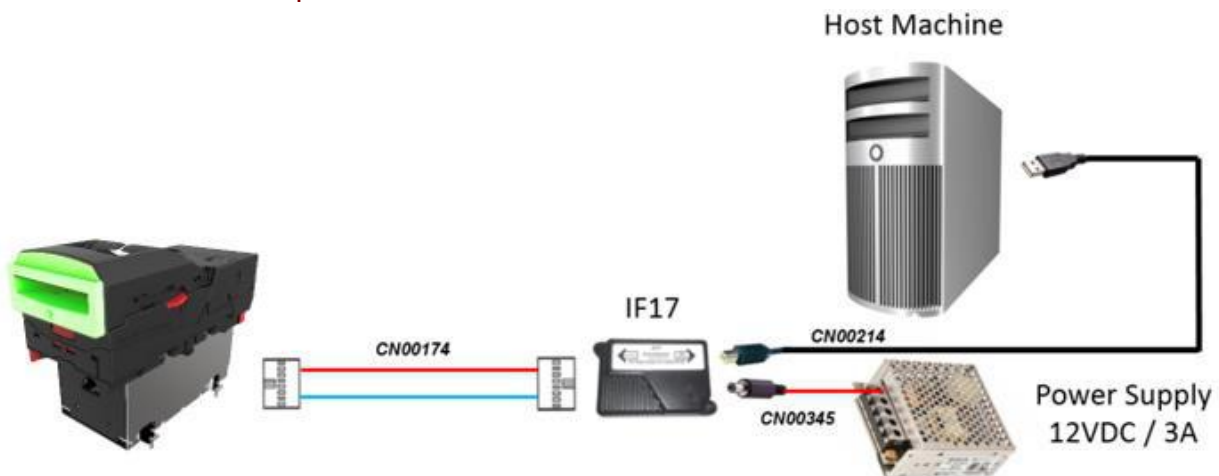

Type	ITL Part Number	Description	Details
Cable	CN00174	NV9 / NV10 Ribbon Cable	http://innovative-technology.com/shop/cables/nv9-nv10-ribbon-cable-detail
Cable	CN00214	USB A to B cable assembly	http://innovative-technology.com/shop/cables/usb-a-to-b-cable-assembly-detail
Cable	CN00345	DA3 / IF17 / IF18 Power Cable	http://innovative-technology.com/shop/cables/da3-if17-if18-power-cable-detail
Interface	IF17	TTL to USB Converter	http://www.innovative-technology.com/shop/accessories/if17-interface-converter-detail



8 FIRST LEVEL SUPPORT

8.1 Bezel LED Flash Codes

The NV9 Spectral Range supports various flash codes that are displayed to the user via the entry bezel. A detailed description of these can be found below.

Interface Flash Codes:

If you double press the red config button the bezel will flash a series of times. Below is a lookup table:

Flashes	Interface	Interface Settings			
		Cct plain	Cct 8-bit	No Escrow Timeout	DES
1	SSP				
6	Cctalk	1	2	3	4

8.2 Bezel/Status LED Flash codes

The NV9 Spectral has inbuilt fault detection facilities. If there is a configuration or other error the NV9 Spectral front bezel will flash in a specific sequence; a summary of the Bezel Flash Codes for the NV9 Spectral is shown below:

8.2.1 NV9 Spectral Bezel Fault codes

Flashes		Indicated Status/Error	Recommended action
Long	Short		
0	0	None	
1	2	Note path jam	Ensure the upper housing assembling is shut down
	3	Unit not initialised	Contact ITL technical support
3	1	Firmware checksum error	Download new firmware
	2	Interface checksum error or unable to set programmed interface	
	3	EEPROM checksum error	
	4	Dataset Checksum	
4	1	Power supply too low	Check power supply
	2	Power supply too high	



8.2.2 Multi Notefloat Status LED Flash codes

Operational Flash codes		
Normal Operation		
LED State	Status	
Rapid flashing	Starting Up	
On	Idle	
Pulse every 3s	Disabled	
Flash until cycle finished	Paying Out	
Error flash codes		
Long	Flashes	Error
3	0	Recovery Mode
3	1	Note Jam
3	2	Sensor Fault
3	3	Tape Fault
3	4	Diverter Fault
3	5	Note Memory is corrupt



8.3 Frequently Asked Questions

Q1. Why are there no DIP switches on the unit?

A: The NV9 Spectral has no dipswitches. Configuring the unit is carried out using a configuration button mounted on top of the unit – see subsection 2.4.4 of this manual for more information.

Q2. In what orientation can I use the NV9 Spectral validator?

A: The NV9 Spectral can be mounted horizontally or vertically, depending on the type of bezel and cashbox selected. check the ITL website to see the currently available range of cashboxes and bezels.

Q3. How do I check which interface has been set?

A: You can check which interface has been selected by using the configuration button mounted on top of the unit – see subsection 2.4.4 of this manual for more information.

Q4. How do I change the interface type?

A: You can change the interface type by using the configuration button mounted on top of the unit – see section [2.4.4](#) of this manual for more information.

Q5. Some or all notes are not accepted

A: Check that no inhibits are set in the Validator Manager software (see section [5](#) of this manual set). If the problem persists, contact ITL Support for further assistance.



9 SECOND LEVEL SUPPORT

9.1 Fault Finding

A flow chart has been generated in the section below for troubleshooting and fault-finding issues that may occur with the NV9 Spectral, this section should be used in conjunction with section [6.1](#).

9.1.1 Notes not accepted

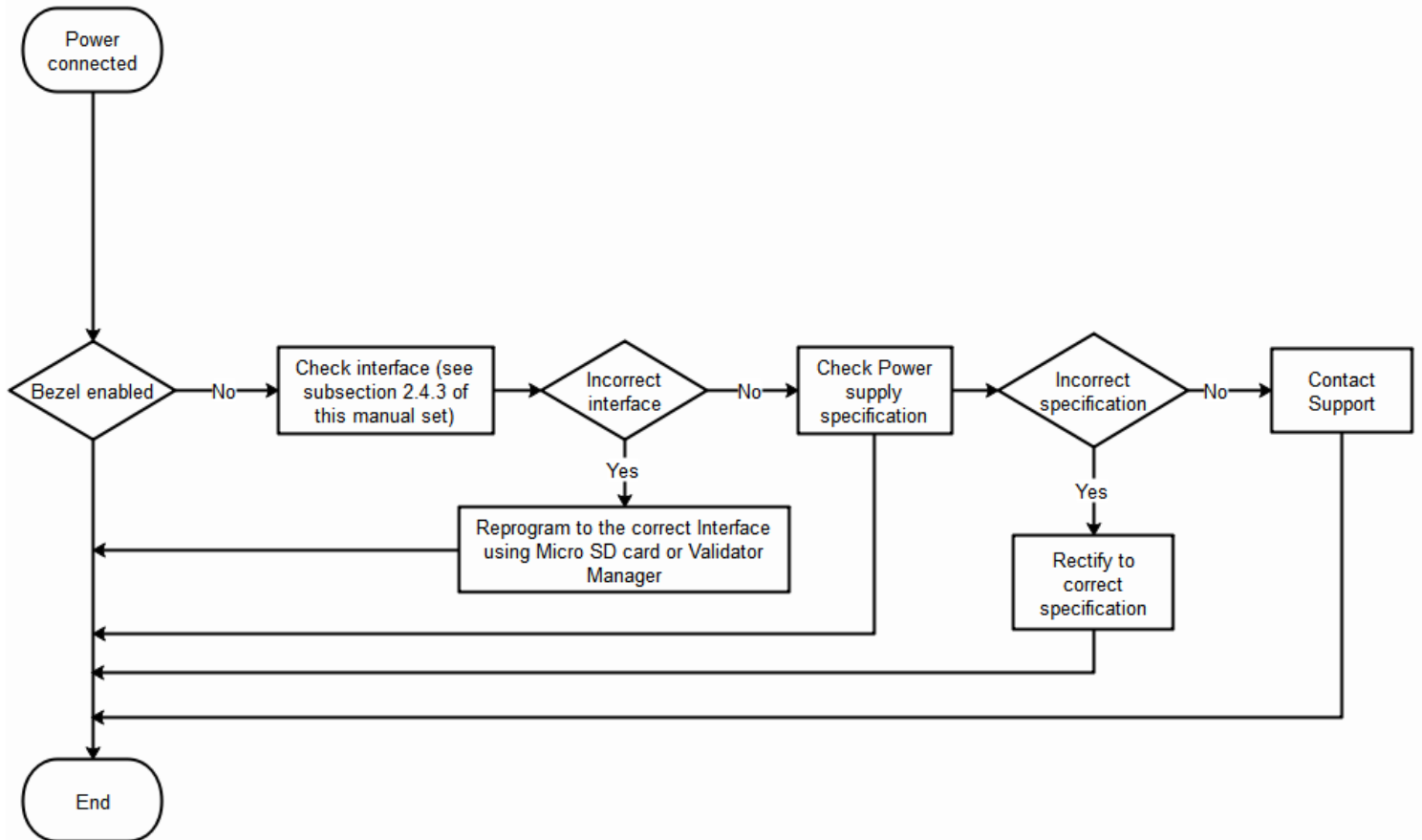

9.1.2 All notes rejected

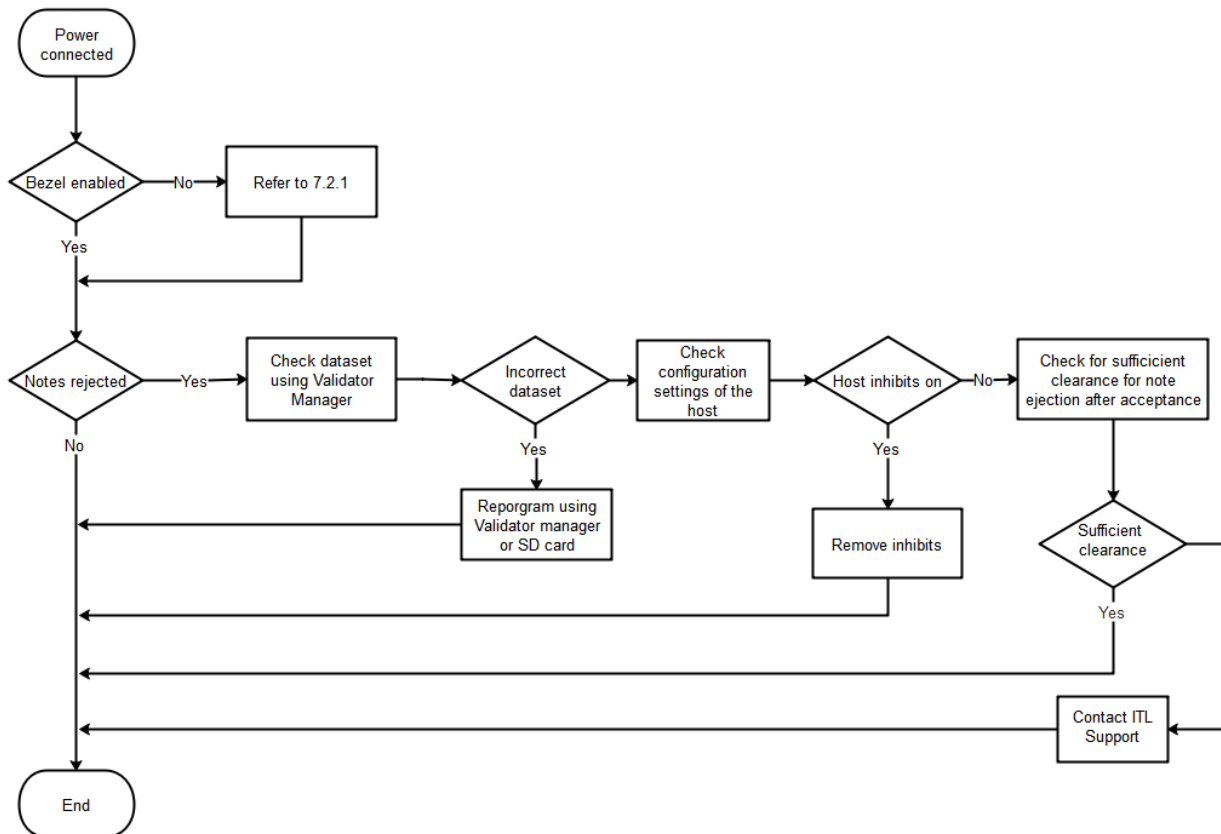

9.1.3 Notes accepted with no credits given

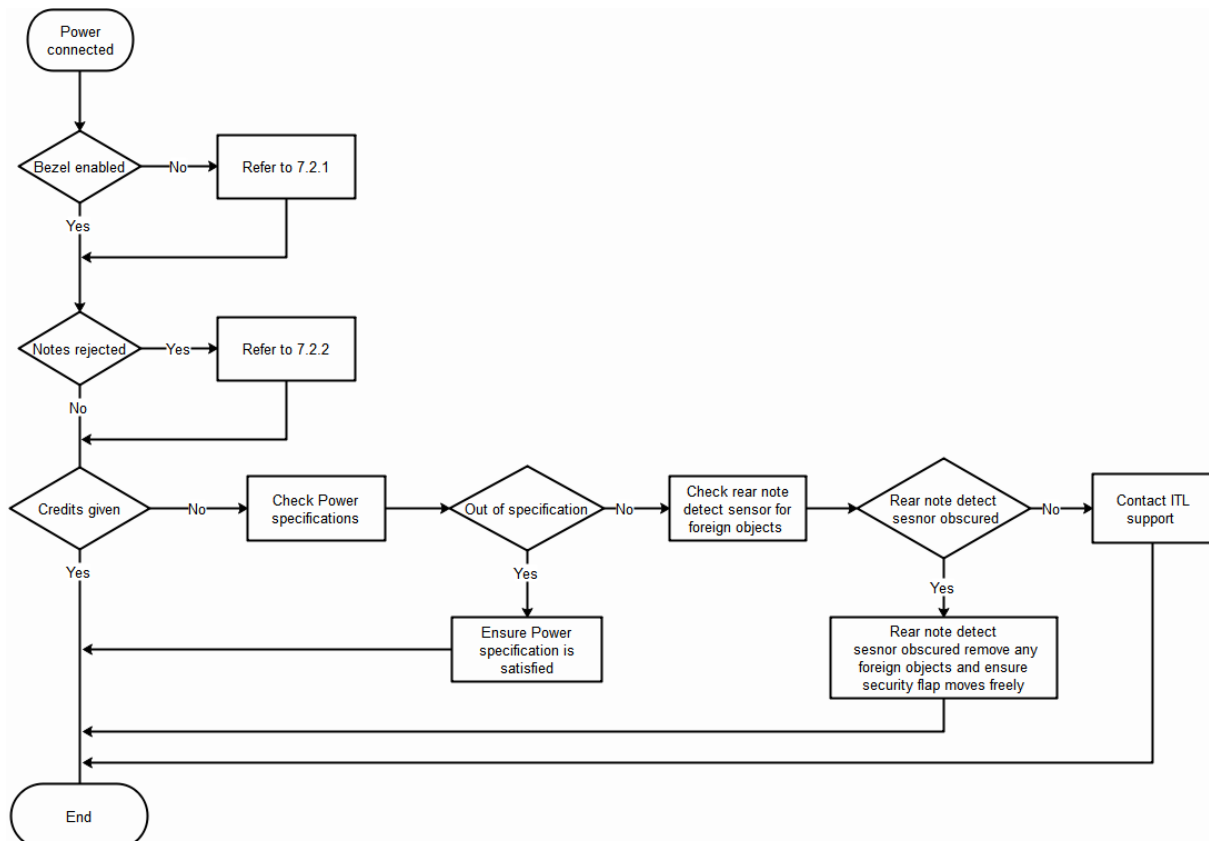

9.1.4 Acceptor runs slowly or continues to run

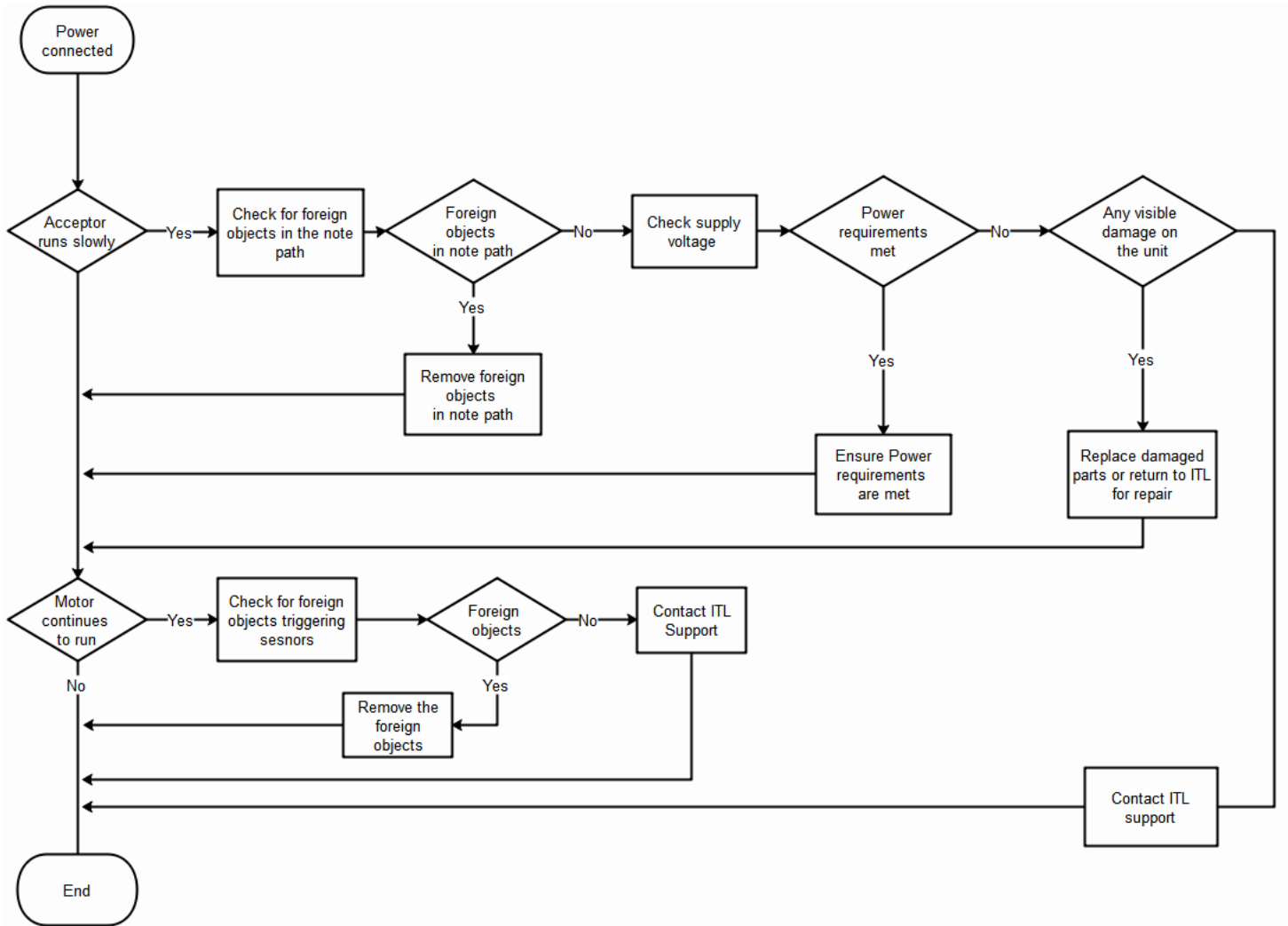

10 APPENDIX

10.1 Cable Drawings

10.1.1 CN214

DRAWING NO. **CN00214**
 ISSUE **A**

Parts List

Item	QTY	Description	Vendor
A	1	USB Type A Male Connector	-
B	1	USB Shielded High Speed 2.0 Cable 28AWG/1P+28AWG/2	-
C	1	USB Type B Male Connector	-

Comments

Note to Manufacturers
 Certificates are needed for the following:
 ■ RoHS compliance ■ UL 94-V0 rated (connector housing) ■ UL 94-VW1 rated (all other parts)

All dimensions are in mm ±5mm, unless specified.

A	B	C	D	E	F	G	H	I	J	K	L	M	N	O	P	Q	R	S	T	U	V	W							
TITLE: USB A to USB B Cable Assembly												DRAWN BY: C. Cardoza		DATE: 15/03/2013		MODIFIED: FRONT		All parts must be marked to all mark (UL, RoHS, VW1, All connector markings must be marked to UL/CEC. Mark the notes complete.											
CHECKED BY: -												DATE: -		ISSUE NO: A		MOD NO: -		DATE: 15/03/2012		C CARDOZA MOD BY: -									

APPROVED FOR CONSTRUCTION
 INNOVATIVE TECHNOLOGY LTD
 15000 HWY 7
 SUITE 100
 RICHMOND, BC V6X 1A7
 TEL: +1(604) 271-8888
 FAX: +1(604) 271-8889
 2012 ALL RIGHTS RESERVED



NV9 Spectral Range Manual

[<< Back to Contents](#)

10.1.2 CN174

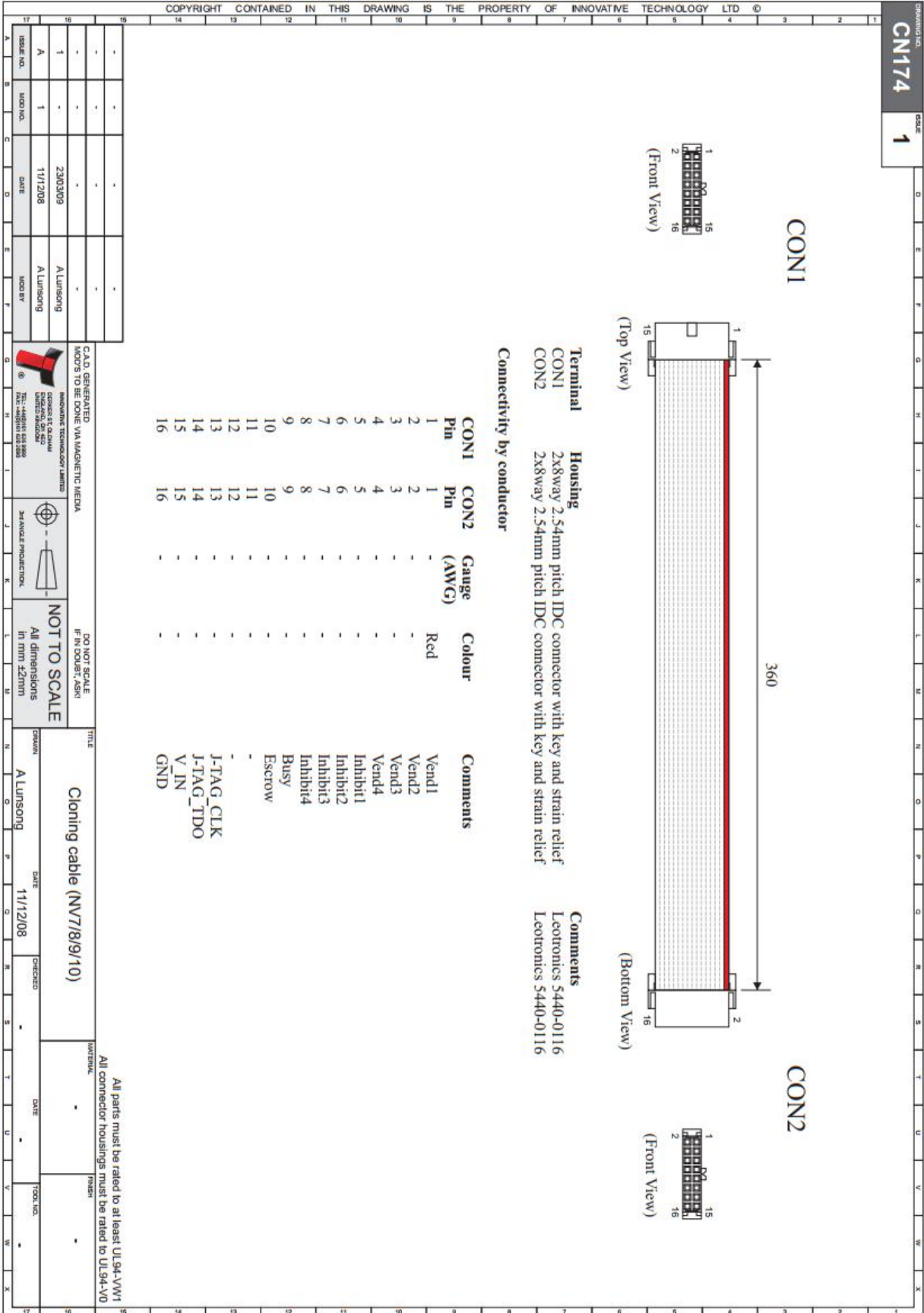

NV9 Spectral Range Manual

[<< Back to Contents](#)

10.1.3 CN392

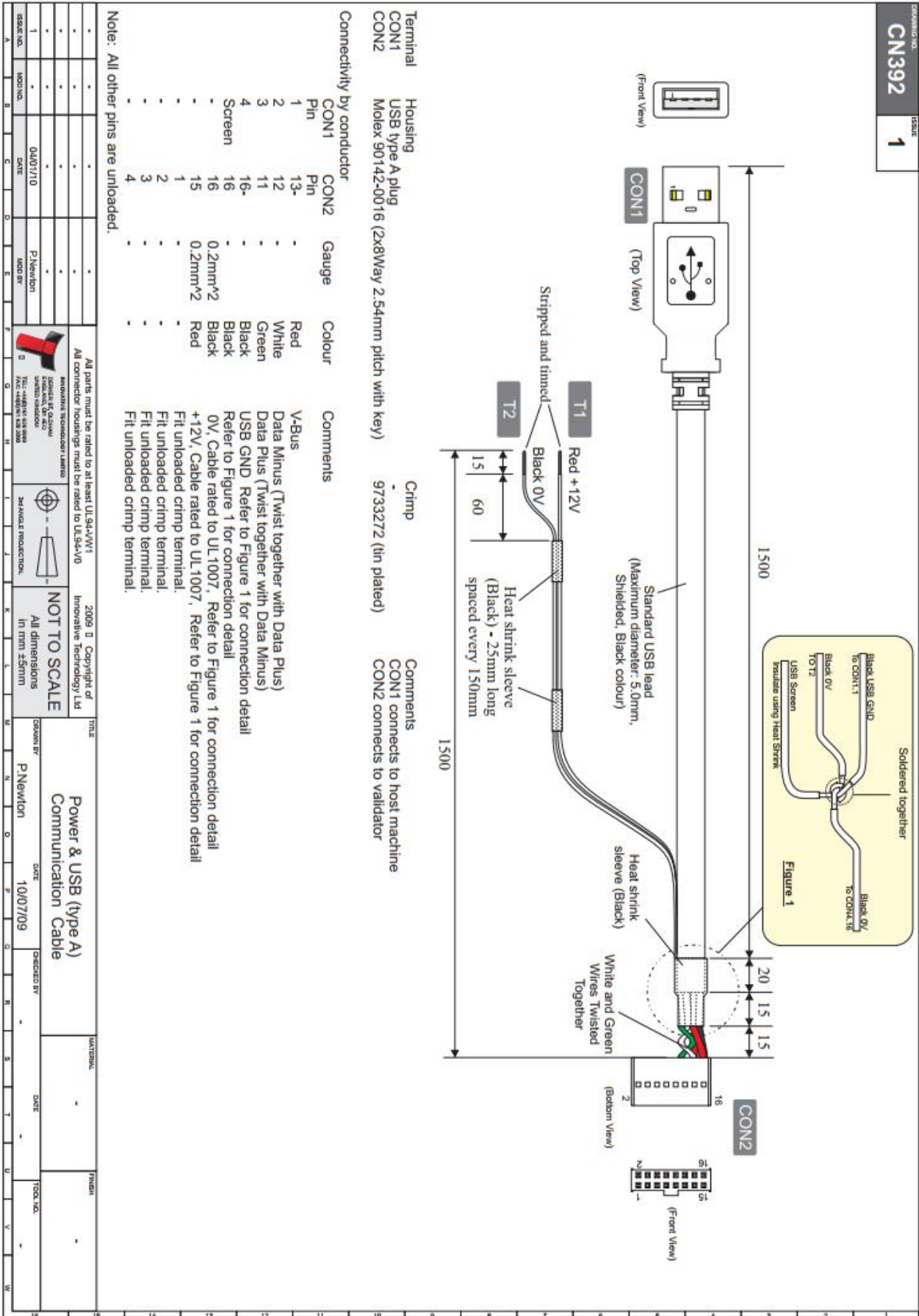

NV9 Spectral Range Manual

[<< Back to Contents](#)

10.1.4 WR02128

CONNECTION NO. **WR02128** SCALE **A**

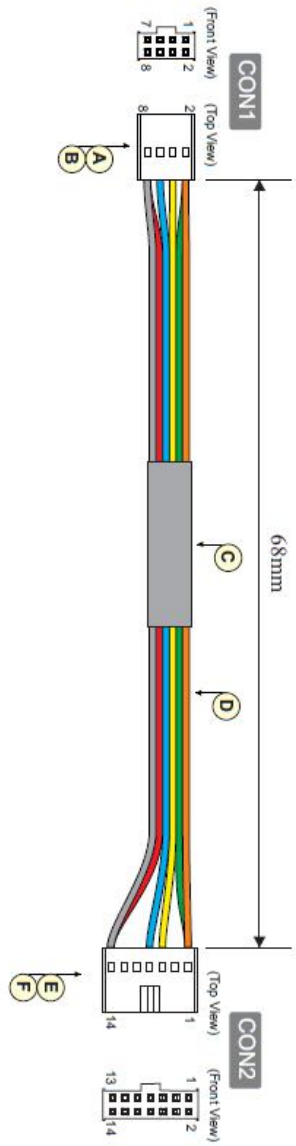

Item	QTY	Description	PIN	Vendor
A	1	24way 2.54mm Pitch Crimp Housing (with key)	69176-008LF	FCI
B	6	Crimp Terminals Tin, 26-32 AWG	47711-001LF	FCI
C	1	20mm Heatshrink sleeve	-	-
D	6	UL1007 Stranded wire	90142-0014	Molex
E	1	2x7way 2.54mm Pitch Crimp Housing (with key)	90119-0120	Molex
F	6	Crimp Terminals Tin, 26-28 AWG	-	-

Notes	Connectivity		Gauge (AWG)	Colour	Comment
	CON1 Pin	CON2 Pin			
	1	1	28	Orange	Vend 3
	2	2	28	Green	Vend 4
	3	3	28	Yellow	Inhibit 3
	5	5	28	Blue	Busy
	7	7	28	Red	Vcc
	8	13	28	Black	Gnd

Note to Manufacturers
 Certificates are needed for the following:
 RoHS compliance UL94-V0 rated (connector housing) UL1591-VW1 rated (heatshrink and wire)

REV	DATE	BY	CHKD	DESCRIPTION
A	27/04/2016	C. Cardaza		NV9 SPECTRAL TO RAINBOW BEZEL CABLE

